



Project Construction Document Specifications

Orange County Convention Center North-South Building Digital Advertising/ Projector Modifications

January 06, 2015

Mechanical
Electrical
Plumbing
Fire Protection
Technology

925 S Semoran Blvd | Suite 100
Winter Park, FL 32792
t: 407.678.2055 f: 407.678.2088

Precise Solutions with Prompt Response

Table of Contents

01100 – Summary of Work
01250 – Contract Modification Procedures
01290 – Payment Procedures
01310 – Project Management and Coordination
01320 – Construction Progress Documentation
01322 – Photographic Documentation
01330 – Submittal Procedures
01400 – Quality Requirements
01500 – Temporary Facilities
01600 – Product Requirements
01700 – Execution Requirements
01731 – Cutting and Patching
01770 – Closeout Procedures
01781 – Project Record Documents
01782 – Operation and Maintenance Data
01820 – Demonstration and Training
06412 - Plastic-Laminate-Faced Architectural Cabinets
16050 – Basic Electrical Material & Methods
16060 – Grounding and Bonding
16072 – Electrical Supports
16075 – Electrical Identification
16120 – Conductors & Cables
16130 – Raceways & Boxes
16140 – Wiring Devices
16289 – Transient Voltage Suppression
16410 – Enclosed Switches & Circuit Breakers
16442 – Panelboards

Mechanical
Electrical
Plumbing
Fire Protection
Technology

925 S Semoran Blvd | Suite 100
Winter Park, FL 32792
t: 407.678.2055 f: 407.678.2088

Precise Solutions with Prompt Response

SECTION 01100 – SUMMARY OF WORK

1) GENERAL

1.1 SUMMARY

- A. This Section includes the following:
 - 1. Work covered by the Contract Documents
 - 2. Work phases
 - 3. Use of premises
 - 4. Owner's occupancy requirements
 - 5. Specification formats and conventions
- B. See Division 1 Section "Summary of Multiple Contracts" for division of responsibilities for the Work.

1.2 WORK COVERED BY CONTRACT DOCUMENTS

- A. Project Identification: Orange County Convention Center North-South Building Digital Advertising/ Projector Modifications.
 - 1. Project Location: 9800 International Drive, Orlando, FL 32819
- B. Prime Consultant: Milan Engineering, Inc. 925 South Semoran Blvd, Suite 100, Winter Park, Florida
- C. The Work consists of the following:
 - 1. This project involves installation of projectors within new custom fabricated housings at the two main entrances on level-2 of the North Building and two main entrances at level-2 of the South Building. Each location will include a 8-projector housing below the walking mezzanine directly in front of the main entrance. Also, a single projector housing shall be installed in front of the bridge projectors on each side of the escalators down to level-1
 - 2. To accommodate the new bridge projector assemblies, contractor shall remove and dispose existing way finding signs including all supports, wiring, and associated components at each location. Also, some relocation of utilities is required to accommodate the new projector housings at these locations.
 - 3. At (4) bridge locations, a new projector housing shall be custom built to house (8) projectors along with miscellaneous electrical and data equipment.

4. In front of the new bridge projectors, an additional projector housing shall be manufactured and installed on each side of the escalator system down to the lower level. This assembly shall house (1) vertical mounted projector.
 5. Projectors and associated components will be provided by the owner and installed inside new custom fabricated assemblies, completely wired and tested by the contractor for this project. The contractor shall engage an EPSON approved subcontractor for installation, wiring and final testing for all of the projectors. Below is a list of owner provided equipment. See Part-2 of this specification for owner's equipment detailed information.
 - a. QTY (40) Pro Z1100WNL Epson Projectors- PN# V11H608920 WXGA, 11000 Lumens No Lens, HDMI & VGA, HDBaseT, 3LCD, Power Zoom & Power Focus, Motorized H&V Lens Shift, (lens not included), Close Caption decoder, DICOM Simulation Mode, 3 Year Warranty.
 - b. QTY (32) Epson Standard Pro Lens - PN# V12H004S04
 - c. QTY (8) Epson Short Throw Lens - PN#V12H004U02
 - d. QTY (40) Finland frames Model ELPMB44/H681.
 6. Structural/ building modifications shall be made at the bridge projectors to accommodate the new projector housings.
 7. Electrical power shall be connected from existing electrical rooms to provide power to the new projectors.
 8. Fiber and Network connections shall be connected from existing IDF rooms to transmit data to the new projectors.
 9. All work shall be performed in a manner and scheduled to reduce disruption to the convention center operations.
 10. The following is a list of EPSON approved installers for the projectors and associated equipment. General contractor shall engage one of the installers for installation, configuration and final testing of the projectors:
 - a. CCS Presentations Systems - John Doster - jcdoster@ccssoutheast.com HQ - Jacksonville, FL t: 904.998.7227 x319 | f: 904.998.7225 m: 904.434.3901 | www.ccssoutheast.com Local office - 7101 Presidents Dr STE 270, Orlando, FL 32809
 - b. Audio Fidelity Communications Group DBA The Whitlock Group Reid Holden, holdenr@whitlock.com. 8010 Woodland Center Blvd., Suite 100, Tampa, FL 33634 www.whitlock.com | www.global-presence.org mobile: 706-206-0680 | direct: 813-498-0404 | Video: 96.254.123.239
 - c. United Data Technologies - HQ Miami, FL, Julia Salas julia.salas@udtonline.com D 786.364.5972 F 305.882.0436 www.UDTOnline.com Local Office 9436 Southridge Park Ct, Suite 800, Orlando FL 32819
- D. Project shall be constructed under a single prime contract.

1.3 WORK PHASES

- A. A phasing plan shall be presented to the Owner representative prior to start of work.
- B. Before commencing Work of each phase, submit a schedule showing the sequence, commencement and completion dates.
- C. Note that all areas of building will be occupied at all times, and contractor shall expect to work around occupants in a safe and effective manner.
- D. Work shall not be performed in public areas during hours of operation where an event or show is scheduled. Schedule all work around convention center show schedule.

1.4 USE OF PREMISES

- A. General: Contractor shall have limited use of premises for construction operations as indicated on Drawings by the Contract limits.
- B. Use of Site: Limit use of premises to areas within the Contract limits indicated. Do not disturb portions of Project site beyond areas in which the Work is indicated.
 - 1. Owner Occupancy: Allow for Owner occupancy of Project site at all times.
 - 2. Driveways and Entrances: Keep driveways and entrances serving premises clear and available to Owner, Owner's employees, and emergency vehicles at all times. Do not use these areas for parking or storage of materials.
 - a. Schedule deliveries to minimize use of driveways and entrances.
 - b. Schedule deliveries to minimize space and time requirements for storage of materials and equipment on-site.
- C. Use of Existing Building: Maintain existing building in a weather tight condition throughout construction period. Repair damage caused by construction operations. Protect building and its occupants during construction period.

1.5 OWNER'S OCCUPANCY REQUIREMENTS

- A. Full Owner Occupancy: Owner will occupy site and building during entire construction period. Cooperate with Owner during construction operations to minimize conflicts and facilitate Owner usage. Perform the Work so as not to interfere with Owner's day-to-day operations. Maintain existing exits, unless otherwise indicated.
 - 1. Maintain access to existing walkways, corridors, and other adjacent occupied or used facilities. Do not close or obstruct walkways, corridors, or other occupied or used facilities without written permission from Owner and authorities having jurisdiction.

2. All work performed in show/ open areas within lobbies and public areas shall be coordinated with owner. All work shall be performed during hours not open to business (10pm to 6am).

1.6 SPECIFICATION FORMATS AND CONVENTIONS

- A. Specification Format: The Specifications are organized into Divisions and Sections using the 16-division format and CSI/CSC's "Master Format" numbering system.
 1. Division 1: Sections in Division 1 govern the execution of the Work of all Sections in the Specifications.
- B. Specification Content: The Specifications use certain conventions for the style of language and the intended meaning of certain terms, words, and phrases when used in particular situations. These conventions are as follows:
 1. Abbreviated Language: Language used in the Specifications and other Contract Documents is abbreviated. Words and meanings shall be interpreted as appropriate. Words implied, but not stated, shall be inferred as the sense requires. Singular words shall be interpreted as plural and plural words shall be interpreted as singular where applicable as the context of the Contract Documents indicates.
 2. Imperative mood and streamlined language are generally used in the Specifications. Requirements expressed in the imperative mood are to be performed by Contractor. Occasionally, the indicative or subjunctive mood may be used in the Section Text for clarity to describe responsibilities that must be fulfilled indirectly by Contractor or by others when so noted.
 - a. The words "shall," "shall be," or "shall comply with," depending on the context, are implied where a colon (:) is used within a sentence or phrase.

2) PRODUCTS (Owner provided, contractor installed)

MODEL		EAI (PowerLite Pro)		Fiw1 (WXGA 11,000lm)	
Projection System		RGB liquid crystal shutter projection system			
Projection Method		Front / Rear / Ceiling mount			
Specification of Main Parts	LCD	Size	1.03-inch wide panel with MLA (D8, C2 Fine)		
		Driving Method	Poly-silicon TFT active matrix		
		Pixel Number	1,024,000 dots (1280 x 800) x 3		
		Native Resolution	WXGA		
		Aspect Ratio	16:10		
		Pixel Arrangement	Cross stripe		
	Projection Lens	Refresh Rate	200 - 240Hz		
		Type	Power zoom / Power focus / Power shift		
		F-Number	1.65 - 2.51		
		Focal Length	36.00mm-57.35mm		
		Zoom Ratio	1 - 1.61		
		Lens Cover	Lens Cap (without string)		
Lamp	Lens exchange	Yes			
	Type	380 W UHE x 2 For Standard-Lamp 304 W UHE x 2 For Portrait			
	Life	2000 hours (Power Consumption: Normal (5) Standard-Lamp 2 Lamps)			
Optical System		Dichroic mirror separation & prism combine method			
Commercial Warranty		20000 hours 0 °C to 50 °C (32°F to 122 °F)			
Screen Size (Projected Distance)		60" to 500" [1.99m to 17.17m] (Zoom: Wide)			
Standard Zoom Lens		60" to 500" [3.26m to 27.77m] (Zoom: Tele)			
		100" screen 3.37 m · 5.49 m			
		Throw ratio: 1.57 (Zoom:Wide), 2.56 (Zoom:Tele)			
Lens Shift Range		Vertical: -60% to +60% (H Center) (Powered)			
		Horizontal: -18% to +18% (V Center) (Powered)			
Standard-Lamp	Light Output (Brightness) (2 Lamps)	Normal (5)	Temp Interlock	11000 lm (Color mode: Dynamic, Zoom: Wide, Lens shift: V Center / H Center)	
		Normal (4)		11000 lm * 0.91 (typical value, not guaranteed) (Color mode: Dynamic, Zoom: Wide, Lens shift: V Center / H Center)	
		Normal (3)		11000 lm * 0.85 (typical value, not guaranteed) (Color mode: Dynamic, Zoom: Wide, Lens shift: V Center / H Center)	
		Normal (2)		11000 lm * 0.78 (typical value, not guaranteed) (Color mode: Dynamic, Zoom: Wide, Lens shift: V Center / H Center)	
		Normal (1)		11000 lm * 0.72 (typical value, not guaranteed) (Color mode: Dynamic, Zoom: Wide, Lens shift: V Center / H Center)	
		ECO		7100 lm (typical value, not guaranteed) (Color mode: Dynamic, Zoom: Wide, Lens shift: V Center / H Center)	
	Light Output (Brightness) (1 Lamp)	Normal (5)	Temp Interlock	5500 lm (typical value, not guaranteed) (Color mode: Dynamic, Zoom: Wide, Lens shift: V Center / H Center)	
		Normal (4)		5500 lm * 0.91 (typical value, not guaranteed) (Color mode: Dynamic, Zoom: Wide, Lens shift: V Center / H Center)	
		Normal (3)		5500 lm * 0.85 (typical value, not guaranteed) (Color mode: Dynamic, Zoom: Wide, Lens shift: V Center / H Center)	
		Normal (2)		5500 lm * 0.78 (typical value, not guaranteed) (Color mode: Dynamic, Zoom: Wide, Lens shift: V Center / H Center)	
		Normal (1)		5500 lm * 0.72 (typical value, not guaranteed) (Color mode: Dynamic, Zoom: Wide, Lens shift: V Center / H Center)	
		ECO		3550 lm (typical value, not guaranteed) (Color mode: Dynamic, Zoom: Wide, Lens shift: V Center / H Center)	
	Color Light Output (Color Brightness)		11000 lm (Color mode: Dynamic, Zoom: Wide, Lens shift: V Center / H Center, Auto iris: Off)		
	Color Light Output (Color Brightness) (1 Lamp)		5500 lm (typical value, not guaranteed) (Color mode: Dynamic, Zoom: Wide, Lens shift: V Center / H Center, Auto iris: Off)		
	Portrait	Light Output (Brightness) (2 Lamps)	8100 lm (typical value, not guaranteed) (Color mode: Dynamic, Zoom: Wide, Lens shift: V Center / H Center)		
		Light Output (Brightness) (1 Lamp)	4050 lm (typical value, not guaranteed) (Color mode: Dynamic, Zoom: Wide, Lens shift: V Center / H Center)		
		Color Light Output (Color Brightness) (2 Lamps)	8100 lm (typical value, not guaranteed) (Color mode: Dynamic, Zoom: Wide, Lens shift: V Center / H Center, Auto iris: Off)		
		Color Light Output (Color Brightness) (1 Lamp)	4050 lm (typical value, not guaranteed) (Color mode: Dynamic, Zoom: Wide, Lens shift: V Center / H Center, Auto iris: Off)		
	Contrast	Auto iris: High Speed / Normal	15000:1 (Color mode : Dynamic, Power Consumption:Normal (5), Zoom: Wide, Lens shift: V -60% or 60% / H Center) * Contrast = 100% White (Iris: Open) / Black (Iris: Close) , Standard-Lamp 2Lamps		
		Auto iris: Off (Native)	1500:1 (typical value, not guaranteed) (Color mode : Dynamic, Power Consumption:Normal (5), Zoom: Wide, Lens shift: V -62% or 62% / H Center) * Contrast = 100% White (Iris: Open) / Black (Iris: Open) , Standard-Lamp 2Lamps		
Light Output Uniformity		90% (Lens shift: V Center / H Center Standard-Lamp 2Lamps)			
Color Reproduction		Up to 1.07billion colors			
Color Processing		10bit			
Color Temperature		White Color mode: Color Temperature, duv Presentation: 7500, 0.015 sRGB: 6500, 0.003 ※reference value			

Video Processing		3D Y/C separation		Yes			
		3D N/R		Yes			
		Mosquito N/R		Yes			
		Super resolution		Yes			
		Frame Interpolation		N/A			
		1080p/24Hz Pulldown Processing		8:8 pull down			
		Directional Correlational Deinterlacing (DCDi)		Yes			
		Motion Adaptive Deinterlacing (MADi)		Yes			
		Motion compensated Interlace-Progressive		Yes			
Internal Speaker(s)		Sound Output		N/A			
		Dimension		N/A			
Remote Control Infrared Receiver Position / Distance / Directivity				Front & Rear (selectable), 30 m *This is the standard number. This is not the guaranteed performance. Front Right / Left : -60 to +60 degrees Lower / Upper : -45 to +15 degrees Rear Right / Left : -30 to +30 degrees Lower / Upper : -40 to +15 degrees			
Function	Image	Color Mode PC	Standard	Iris	Default	Cinema Filter	
				Dynamic	Yes	High Speed	N/A
				Presentation	N/A	-	N/A
				Theatre	Yes	High Speed	Yes
				Photo	N/A	-	N/A
				sRGB	N/A	-	Yes
				DICOM SIM	N/A	-	N/A
				Multi-Projection	N/A	-	N/A
			3D Images	Iris	Default	Cinema Filter	
				3D Dynamic	Yes	Off	N/A
				3D Presentation	N/A	-	N/A
				3D Theatre	Yes	Off	Yes
				3D Multi-Projection	N/A	-	N/A
		Color Mode Video	Standard	Iris	Default	Cinema Filter	
					Dynamic	Yes	High Speed
				Presentation	N/A	-	N/A
				Theatre	Yes	High Speed	Yes
				Sports	N/A	-	N/A
				sRGB	N/A	-	Yes
				Multi-Projection	N/A	-	N/A
			3D Images	Iris	Default	Cinema Filter	
				3D Dynamic	Yes	Off	N/A
				3D Presentation	N/A	-	N/A
				3D Theatre	Yes	Off	Yes
				3D Multi-Projection	N/A	-	N/A
		Brightness		Yes			
		Contrast		Yes			
		Color Saturation		Yes			
		Tint		Yes			
		Sharpness	Standard	Yes			
			Advanced	Thin Line Enhancement,Thick Line Enhancement,Vert. Line Enhancement,Horiz. Line Enhancement			
		Color Temp.		Yes			
		Advanced	Gamma	9 points of gamma curve are adjustable			
			RGB	R (red), G (green), and B (blue) components of the offset and gain are adjustable			
			RGBCMY	Hue / Saturation / Brightness for each of RGBCMY are adjustable			
		Auto Iris		OFF / High Speed / Normal (Dynamic, Theatre, 3D Dynamic, 3D Theatre only)			
		Reset		Yes			
	Signal	3D Setup	3D Images	Color Mode 3D Images On/Off			
				Auto Setup		Yes	
		Resolution		Auto, Wide, Normal, Manual			
		Tracking		Yes			
		Sync.		Yes			
		Position		Yes			
		Progressive		Off, Video, Film/Auto			
		Frame Interpolation		N/A			
		Super-resolution		Yes			
		Noise Reduction		Yes			
		Mosquito NR		Yes			
		HDMI Video Range		Yes			
		SDI Video Range		N/A			
		Display Port Video Range		N/A			
		Input Signal		Auto, RGB, and Component			
		Video Signal		Yes			
		Aspect		Yes			
		Scale		Yes			
		Overscan		Yes			
		Image Processing		Fine / Fast			
		Reset		Yes			
	Settings	Geometric Correction	Off	Yes			
			V Keystone	-30 degrees to +30 degrees (Zoom: Tele with Standard Zoom Lens) -24.5 degrees to +24.5 degrees (Zoom: Tele with Short Throw Zoom Lens)			
			H Keystone	-30 degrees to +30 degrees (Zoom: Tele with Standard Zoom Lens) -18.5 degrees to +18.5 degrees (Zoom: Tele with Short Throw Zoom Lens)			
			Quick Corner	Yes			
			Arc	N/A			
			Curved Surface	Yes			
			Point Correction	Yes			
		Corner Wall	Yes				
		Split Screen	Yes				
		Control Panel Lock	Yes				
		Lens Operation Lock	Yes				

	Power Consumption	Normal / Temp Interlock / ECO (Standard-Lamp only) Normal :The projector works at temperatures up to 45°C (113 °F) . ECO :The projector works at temperatures up to 50°C(122 °F) . Temp Interlock :The projector works at 100% brightness at temperatures up to 45°C (113 °F) . When the ambient temperature exceeds 45 °C (113 °F) , the projector can continue to work by decreasing the lamp power gradually down to the same level as Eco mode	
	Volume	N/A	
	Remote Receiver	Yes	
	User Button	Yes (User Button x 3)	
	Test Pattern	Yes (11 test patterns)	
	Memory	Memory 1 - 10 (It is possible to edit memory names.)	
	Reset	Yes	
Extended	Display	Menu Position	Yes
		Message Position	Yes
		Messages	Yes (On/Off)
		Display Background	Black, Blue, or Logo
		Startup Screen	Yes
		Standby Confirmation	Yes(On/Off)
		Air Filter Notice	Yes
		Screen	Screen Type, Screen Position
		Panel Alignment	Yes
		Color Uniformity	Yes
	Closed Caption	Yes (EAI only)	
	User's Logo	Yes	
	Projection	Yes	
	Direction	Yes	
	Operation	Direct Power On	Yes (On/Off)
		Sleep Mode	Yes
		Sleep Mode Timer	Yes
		Shutter Timer	Yes
		High Altitude Mode	Yes
		Startup Source Search	Yes
		Auto Power On	Off / Computer / BNC (Standby Mode: Communication On only).
		BNC Sync Termination	Yes
		Remote Control Type	Yes
		Shutter Button	Shutter / Blank
		Shutter Release	Any Button / Shutter
Beep		Yes	
Indicators		Yes	
Lens Type		Yes	
Instant Off		Yes(Enabled/Disabled)	
Date & Time	Yes		
Output Settings	External Output	Always On / While Projecting	
	Monitor Out	Yes	
	Audio Settings	N/A	
Standby Mode	Communication On, Off		
HDBaseT	Control Communications	On/Off	
Multi-Projection	Projector ID , Scale, Color Mode, Color Uniformity Edge Blending, Brightness Level 5/4/3/2/1 (Power Consumption: Standard-Lamp Normal only), Color Matching, RGBCMY, Black Level, Reset		
	Lamp Select	Dual / Single / Lamp1 / Lamp2	
	Schedule Settings	Yes (Added lamp-relay)	
	Language	Yes	
	Reset	Yes	
	Net. Info. - Wireless LAN	Yes	
	Net. Info. - Wired LAN	Yes	
Network Configuration	Yes		
Network	Info Menu (Display Only)	Yes (Added firmware version)	
	Reset All	Yes	
Reset	Reset Memory	Yes	
	Auto Keystone Correction	N/A	
Quick Setup	N/A		
Source Search	Yes		
Auto Detection of RGB/Component	Yes		
Wall Shot	N/A		
Auto Focus Function	N/A		
Pointer	N/A		
E-Zoom	Yes		
Freeze	Yes		
Help	Yes		
PIP	N/A		
Preview	N/A		
Password Protected Function (Security Function)	Yes (Protection of User logo, Power On, Network,Time/Schedule)		
Remote Control Lock	Yes		
Serial number display(OSD, Monitor,VP21)	Yes		
Auto lamp timer reset (Lamp with fuse)	Yes		
On-Screen Display	Yes(On/Off) (User Button only)		
Protocol Emulation	Yes (Hidden function)		
Projector configuration data function	Yes		
Shutter	Yes (Faster shutter speed)		
Frame Interpolation demo	Yes (Hidden function)		
Super-resolution demo	Yes (Hidden function)		
Status Monitor	Yes LCD monitor		
Back-light	Yes for Status Monitor and Operation Pannel		
Effective Scanning Frequency Range (Analog)	Pixel Clock	13.5 MHz to 162 MHz up to UXGA 60 Hz	
	Horizontal	15 kHz to 92 kHz	
	Vertical	50 Hz to 85 Hz	
Effective Scanning Frequency Range (HDMI)	Pixel Clock	13.5 MHz to 162 MHz up to UXGA 60 Hz	

		Horizontal	15 kHz to 75 kHz
		Vertical	24Hz 30Hz 50 Hz 60Hz
Effective Scanning Frequency Range (SDI)		Pixel Clock	N/A
		Horizontal	N/A
		Vertical	N/A
Analog RGB I/O	Display Performance	Native	1280 x 800 dots
	Input Signal	Signal Type	Separate signal
		Video Signal	Analog (0.7 Vp-p, 75 ohm / Mac 0.714 Vp-p, 75 ohm)
		Sync. Signal	Separate (positive & negative, bi-polarity 2-5 Vp-p) / Composite (positive & negative, bi-polarity 2-5 Vp-p) / Sync on green (negative, 0.3 Vp-p)
		Audio Signal	N/A
	Input Terminal	Video	D-sub 15pin x 1 Blue molding 5-BNC x1
		Audio	N/A
	Output Signal	Video Signal	Analog (0.7 Vp-p, 75 ohm / Mac 0.714 Vp-p, 75 ohm)
		Sync. Signal	Separate (positive & negative,TTL) / Composite (positive & negative,TTL) / Sync on green (negative 0.2-0.4 Vp-p)
	Output Terminal	Video	D-sub 15pin x 1 Black molding (Output signal : Computer ,5-BNC only)
Audio		N/A	
Video I/O	Display Performance		Composite input: NTSC:480line , PAL: 576 lines (Depend on observation of the multi-burst pattern)
	Input Signal	Video Standard	NTSC / NTSC4.43 / PAL / M-PAL / N-PAL / PAL60 / SECAM
		Video Signal	Composite Video (1.0 Vp-p / Sync.negative, 75 ohm) / S-Video (Luminous 0.714 Vp-p, Chrominous 0.286 Vp-p, 75 ohm) / Component Video (Analog Y level 0.7 V, 75 ohm / Cr Cb level +/-0.35 V, 75 ohm / sync. negative 0.3 V or 3-state +/-0.3 V on Y) / RGB Video (0.7 Vp-p, 75 ohm / Mac 0.714 Vp-p, 75 ohm)
		Audio Signal	N/A
	Input Terminal	Video	Composite Video:1-BNC S-Video: Mini DIN Component Video: 5-BNC,Mini D-sub 15pin x 1 Blue-molding (in common with Analog RGB connector) Video-RGB:5-BNC, Mini D-sub 15pin x 1 Blue-molding (in common with Analog RGB connector)
Audio		N/A	
HDMI	Display Performance	Native	1280 x 800 dots (WXGA)
	Input Signal	Features	Specific features are not supported.
		Resize	Video Standards up to 1080p, PC standards up to UXGA-60, Wide PC Standards up to WXGA60 . Refer to Compatible mode (WXGA)
		Video Standard	480i / 576i / 480p / 576p / 720p / 1080i / 1080p
	Video Signal	TMDS(TMDS is signal for HDMI)	
	Audio Signal	N/A	
Input Terminal	HDMI x 1		
		HDCP	Yes
DisplayPort	Display Performance	Native	N/A
	Input Signal	Features	N/A
		Video Signal	N/A
		Audio Signal	N/A
	Input Terminal		N/A
		DPCD	N/A
DVI-D	Display Performance	Native	1280 x 800 dots (WXGA)
	Input Signal	Resize	Video Standards up to 1080p,PC standards up to UXGA-60,Wide PC Standards up to WUXGA-60 RB. Refer to Compatible mode (WXGA)
		Video Standard	480i / 576i / 480p / 576p / 720p / 1080i / 1080p
		Video Signal	TMDS(TMDS is signal for DVI)
	Input Terminal	Video	DVI TypeD x 1
		Audio	N/A
		HDCP	Yes
SDI	Display Performance	Native	N/A
	Input Signal	Resize	N/A
		Video Standard	N/A
		Video Signal	N/A
	Input Terminal	Video	N/A
Audio		N/A	
USB Display	Display Performance	Native	N/A
	Input Signal	Video	N/A
		Audio	N/A
HDBaseT (Rx)	Input Signal	Certification	CTS1.1
		HDMI(Video)	Yes CEC=NotSupported
		RS232C	Yes
		IR	Yes EPSON Remote Control Only (Supported;Tx>Rx Direction)
		Wired LAN	Yes (Supported;100BaseT only)
	Power on Ethernet (PoE)	N/A	
	Input Terminal		RJ45 x 1
Control I/O	USB I/O	I/O Terminal	N/A
		I/O Speed	N/A
	Serial I/O	I/O Terminal	D-sub 9pin x 1
		I/O Signal	RS-232C
	Remote Control Input	Input Terminal	Stereo mini-jack x 1
Input Signal		EPSON Format	
	Memory I/O		N/A
Network I/O	USB I/O	Wired LAN	RJ45 x 1 100Mbps
		I/O Terminal	Type A x1 Supported Wireless LAN unit Optional Accessories only

		Supported Ethernet unit	N/A
Wireless specification	Supported Speeds for each mode		IEEE 802.11b: 11 Mbps* IEEE 802.11g: 54 Mbps* IEEE 802.11n: 130 Mbps* *Maximum speed and range is achievable when used with same enhanced mode technology. Actual data rates, features and performance may vary depending on your computer system, the environment and other factors.
	Supported mode		Adhoc, Infrastructure, Soft AP
	Certification		Wi-Fi CERTIFIED (for Wireless LAN unit)
	Frequency type (modulations)		DSSS/CCK, OFDM
Service	USB I/O	I/O Terminal	USB Type B x 1 (for download)
		I/O Speed	USB Ver. 2.0
	MIC		N/A
Operating Temperature		0 ° C to 50 ° C (32° F to 122 ° F) (20% - 80% humidity, unfrozen) Thermal shut down > Normal1 50 ° C (122 ° F),ECO & Normal2 55°C(131°F)	
Operating Altitude		0 m to 3048 m(0 ft to 10000 ft) (over 1500 m / 4,921 ft :with High altitude mode) *ECC model Only 0m to 2000m(0 ft to 6,562 ft) (over 1500 m / 4,921 ft :with High altitude mode)	
Storage Temperature		-10 °C to 60 °C(14°F to 140 °F) (10% - 90% humidity, unfrozen)	
Operating Angle of Tilt		Standard-Lamp Tilt/Roll : ± 100° / ± 5° Portrait Tilt/Roll : ± 10° / ± 10° Placed with the air filter side surface facing downward	
Direct Power On		Yes	
Direct Power Off		Yes	
Auto Power On		Yes	
Start-up Period		about 20 seconds warm-up period: 30 seconds	
Cool-down Period		Instant off or 0 second	
Exhaust Direction		Rear	
Intake Direction		Side	
Foot Adjuster	Tilt Angle	-3.5 to 3.5 degrees	
	Direction	Front side, Rear side	
Focus Balance Adjustment		N/A	
Air Filter	Maintenance Cycle	10000H *When used in the general office environment (the amount of floating dust: 0.04-0.2 mg/m ³). Based on the Epson's in-house test results. 25°C(77°F)	
	Air Filter Notice	Yes	
Theft Proof	Security Cable Hole	Yes	
	Kensington Lock	Yes	
	Lens Lock	N/A	
	Wireless LAN Unit Lock	N/A	
Power Supply Voltage		100 - 240 V AC ±10%, 50/60 Hz	
Power Consumption	100-120V Area (JAPAN, USA, etc)	Lamp On (Power Consumption: Normal (5), Standard-Lamp 2 Lamps)	1120 W
		Lamp On (Power Consumption: ECO, Standard-Lamp 2 Lamps)	821 W
		Network Standby	2.7 W
		Standby	0.26 W
		Rated Voltage & Current	100 - 240 V AC 50/60 Hz 11.2 - 4.9 A
	220-240V Area (Europe, etc)	Lamp On (Power Consumption: Normal (5), Standard-Lamp 2 Lamps)	1060 W
		Lamp On (Power Consumption: ECO, Standard-Lamp 2 Lamps)	788 W
		Network Standby	2.9 W
		Standby	0.37 W
		FAN Stop	Standby, Network Standby
Dimension	Exclude Feet (D x W x H)		741 × 534 × 197 mm ... 29.17 x 21.02 x 7.76" (not including foot, projection lens and handle)
	Maximum Dimension (D x W x H)		741 × 534 × 255 mm ... 29.17 x 21.01 x 10.04"
Weight		Approx. 26kg/58lb (Including Standard Zoom Lens)	
Fan Noise (Standard-Lamp 2 Lamps)	Power Consumption: Normal (5)		40 dB
	Power Consumption: ECO		<
Fan Noise (Standard-Lamp 1 Lamp)	Power Consumption: Normal (5)		40 dB
	Power Consumption: ECO		<
Cooling Method		Liquid-cooling	
Compatible Standard	Safety	US	UL60950-1 2nd edition (eTUVus Mark)
		Canada	CSA C22.2 No.60950-1-07(eTUVus Mark)
		Japan	The electrical appliance safety law / TV receiver
		Europe	Low Voltage Directive (2006/95/EC) (CE Marking)
		Germany	German Equipment and Product Safety Law (GS Mark)
		Korea	Electrical Appliances and Materials Safety Control Law (KC Mark)
		China	Regulations for Compulsory Product Certification GB4943 (CCC Mark)
		Singapore	Singapore Consumer Protection (Safety Requirement) Registration Scheme (Singapore Safety Mark)
		Argentina	Resolution 92/98 or Electric Security standards (Argentina S-mark)
		Russia /Belarus /Kazakhstan	Technical regulation of Customs Union (EAC mark)
	EMC	Mexico	NOM-001-SCFI (NOM mark)
		US	FCC part 15B class B
		Canada	ICES-003 class B
		Japan	The electrical appliance safety law / TV receiver
		Europe	EMC directive (2004/108/EC) (CE Marking)
		Germany	German Equipment Safety Law (GS-mark)
		Korea	Electrical Communication Basic Law (KC Mark)
		China	Regulations for Compulsory Product Certification GB9254 GB17625.1 (CCC mark)

		Australia/New Zealand	AS/NZS CISPR22 Class B (RCM Mark) (not comply with CE Marking)	
		Russia /Belarus /Kazakhstan	Technical regulation of Customs Union (EAC mark)	
	Destination		Limited by the radio system standards and the export administration regulations.	
Supported Languages	OSD		W.W. :27 languages Japanese / English / French / Germany / Italian / Spanish / Portuguese / Korean / Chinese / Russian / Dutch / Danish / Hungarian / Czech / Polish / Norwegian / Finnish / Swedish / Greek / Turkish / Arabic / Traditional Chinese / Romanian / Slovenian / Ukrainian / Catalan / Thai ECC :5 languages Japanese / English / French / Germany / Chinese	
	Manual		26 languages Japanese / English / French / Germany / Italian / Spanish / Portuguese / Simplified Chinese / Russian / Dutch / Danish / Hungarian / Czech / Polish / Norwegian / Finnish / Swedish / Greek / Turkish / Arabic / Traditional Chinese / Romanian / Slovenian / Ukrainian / Catalan / Kazakh	
Easy MP Part	Projector control and projector management via network	E-mail notification	Yes	
		SNMP	Yes	
		Web control	Yes	
		Secure HTTP	Yes	
		Web Remote	Yes	
		PJLink	Yes	
		AMX	Yes	
		Device Discovery		
		Extron IP Link	Yes	
		Extron XTP	Yes	
	Crestron	Yes		
	Integrated Partner / RoomView			
		PC Free	N/A	
		Network Presentation	Yes	
		Multi PC Projection	Yes	
		Windows Network Projector	N/A	
		Transferring or writing files to memory card from	N/A	
		Message Broadcasting	Yes	
		Quick Wireless Connection	Yes	
		PC applications	EasyMP Monitor Ver.4.54 (for Windows) EasyMP Network Projection Ver.2.85 (for Windows) ,Ver.2.83 (for Mac) WUXGA native resolution transfer Movie Sending N/A EasyMP Multi PC Projection Ver.1.21 (for Windows), Ver1.20(for Mac) (with Moderator function) Quick Wireless Connection Ver.1.32(for Windows) EPSON iProjection Ver.1.22 for iOS EPSON iProjection Ver.1.22 for Android EasyMP Monitor Plug-in Message Broadcasting Ver.1.02 EasyMP Monitor Plug-in Service Menu Viewer Ver.1.04 EasyMP Network Updater Ver.1.20 (with projector configuration data function)	
	Wireless LAN Security	WPA-PSK(TKIP/AES)/ WPA2-PSK(TKIP/AES)		
Supplied Accessories	Power Cord		3 m, 3 Wire (White or Black) EAL:Black	
	Computer Cable		1.8 m D-sub 15pin (Male) · D-sub 15pin(Male)	
	USB Cable		N/A	
	Remote Control		attached (New)	
	Battery		Alkaline AA x 2	
	Soft Carrying Case		N/A	
	Wireless LAN unit		N/A	
	Quick Wireless Connection USB Key		N/A	
	Bundled Software		attached CDROM (Projection Software Ver.1.11e)	
	Lens Lock Screw		N/A	
	Password Protect Sticker		N/A	
	User's Manual Set		attached	
	HDMI Cable Clamp		attached (Same as Belgium)	
	Power Cord Clamp		attached(New)	
	Foot Cover		attached	
	Optional Accessories	Spare Lamp		ELPLP81 (2 lamps Set: ELPLP82) (New) for Standard-Lamp ELPLP83 (2 lamps Set: ELPLP84) (New) for Portrait
		Air Filter		ELPAF46 (New)
		Wireless LAN unit		ELPAP07
		Quick Wireless Connection USB Key		ELPAP09
		Soft Carrying Case		N/A
Hard Carrying Case			N/A	
Computer Cable		HD15 / HD15, 1.8 m		ELPKC02
Computer Cable		HD15 / HD15, 3.0 m		ELPKC09
Computer Cable		HD15 / HD15, 20.0 m		ELPKC10
Component Video Cable		HD15 / 3RCA (male), 3.0 m		ELPKC19
HD-TV Cable		HD15 / D, 3.0 m		ELPKC22 (only for EHC)
Remote Control		10m x2		ELPKC28
Cable Set				
HDBaseT Transmitter				ELPHD01
Polarizers				ELPPL01
Passive 3D Glasses				ELPGS02A x 5 ELPGS02B x 5
Ceiling Mount		White color		ELPMB25,ELPMB26
Pipe		White color		N/A
Image Presentation Camera				ELPDC11,ELPDC20
Frame				ELPMB44 (New)
Mouse Receiver			ELPST16	
Option Lens	Short Throw Zoom Lens		ELPLU02 (New)	
	Rear Projection Wide Lens		ELPLR04	
	Wide Zoom Lens		ELPLW04	
	Standard Zoom Lens		ELPLS04	
	Middle Throw Zoom Lens1		ELPLM06	
	Middle Throw Zoom Lens2		ELPLM07	

	Long Throw Zoom Lens	ELPLL07
60"	Portable Roll Screen 4:3	ELPSC27
80"	Portable Roll Screen 4:3	ELPSC28
100"	Portable Roll Screen 4:3	ELPSC29
70"	Portable Roll Screen 16:10	ELPSC23
80"	Portable Roll Screen 16:10	ELPSC24
90"	Portable Roll Screen 16:10	ELPSC25

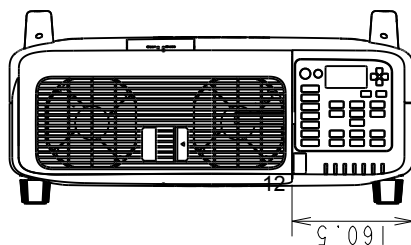
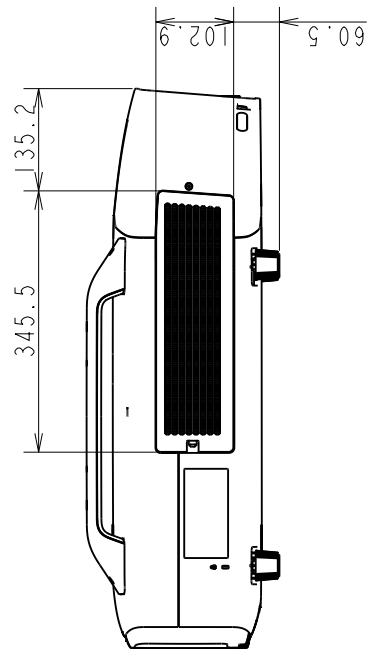
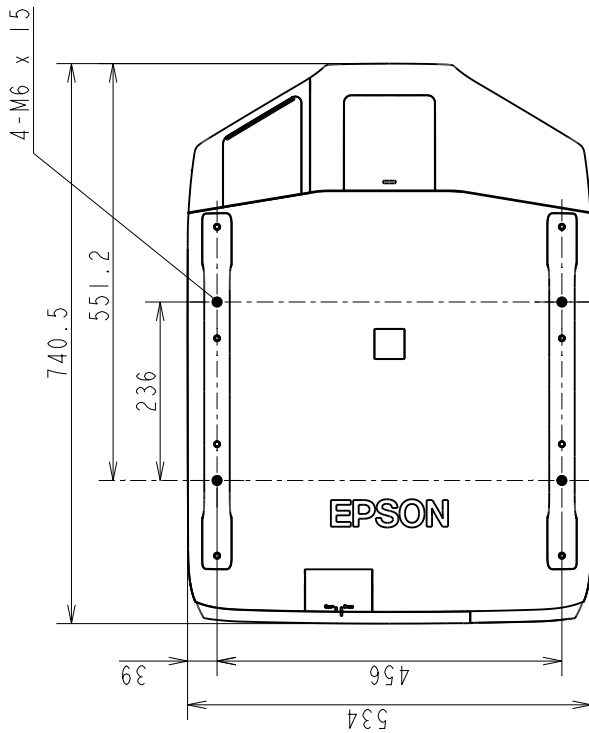
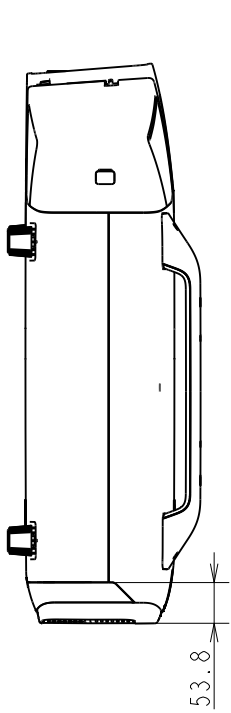
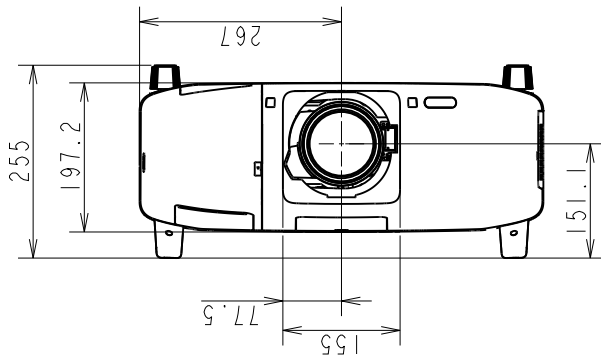
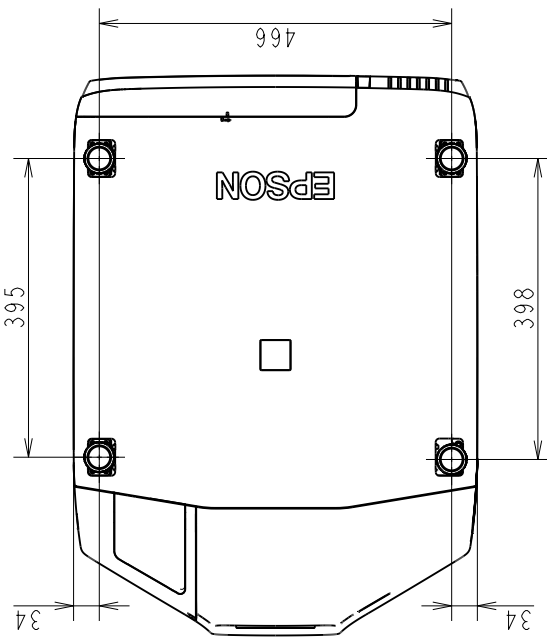

PROZ - Frame

MODEL		ELPMB44 / H681		
Product name		Frame		
Supported projector		Finland, Norway, Norway-UG		
Orientation	Landscape	yes		
	Stack (Landscape)	yes *Stack maximum : 2 *It can use with small projector *Backup projector can be put on the stacked Finland frame.		
	Portrait	yes *Finland: Place the surface of air filter side to the bottom. *Norway and Norway-UG are not available		
	Portrait & Stack	Not available		
	Upper	yes		
	Under	yes		
Structure	Shape	refer the attached file		
	Projector fixing	On to Roof rail		
	Frame shape	Round		
	Frame diameter	Around 30mm (Outer frame)		
	Frame material	Steel		
	Decoration	Painting (Black)		
	Print (EPSON Logo)	Yes		
Dimensions	Size (D×H×W)	Less than 910 (D) × 394 (H) × 734 (W) [mm] Include Foot Without projection		
	Packing (D×H×W)	Less than (1030 (D) × 514(H) × 854(W)) [mm]		
Weight	Body	Less than 23 [kgf]		
	Packing	Less than 40 [kgf]		
Specification of Adjustment mechanism	Angle Adjustment	Axis	Vertical tilt adjustment Horizontal rotation adjustment Horizontal roll adjustment	
		Structure	Independent 3 axes	
		Tool	Screw	
	Adjustment range	Vertical tilt	+/- 5.0degree	
		Horizontal rotation	+/- 5.0degree	
		Horizontal roll	+/- 2.0degree	
		Horizontal slide	nothing	
		Forward/backward slide	nothing	
	Angle Adjusting Lock	Screw		
	Stacking Fix	By screws (The screws must be stored on somewhere on frame.)		
Foot	Adjustable(10mm or above)			
Quality	Durability (guarantee)	30kgf *1x loads for Finland weight		
	Backup Stack Durability (guarantee)	15kgf (Korea-UG/Belgium/Nepal)		

Product image

Dec 10, 2013
Draft Rev.A
Confidential

Dimension (Include Foot / Without projection) (TBD)

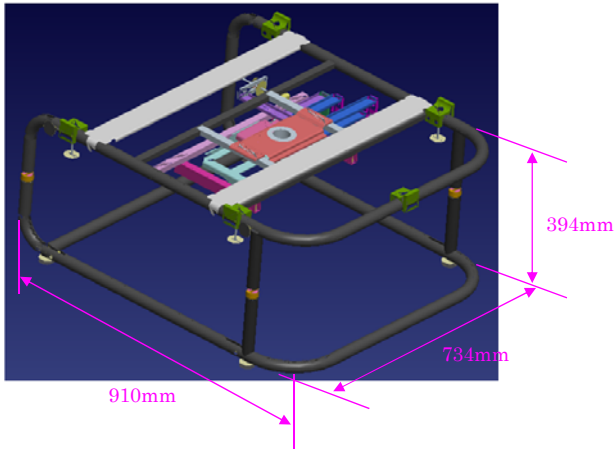

Adjustment range

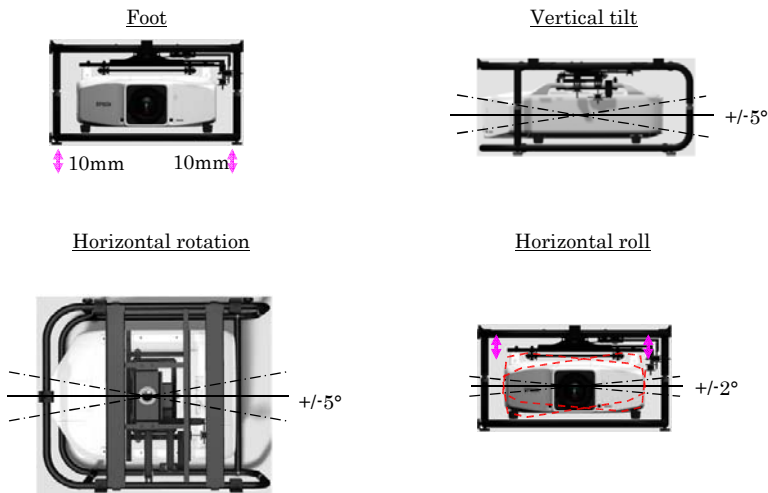

Position of adjustment dial.

Each adjustment functions are controlled by adjustment dial.

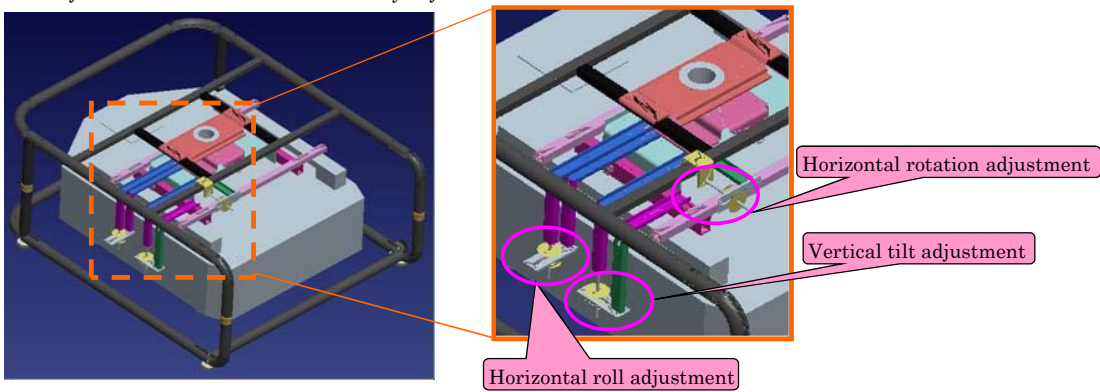

Use case/Orientation

Landscape



Stack (Landscape)



With small backup projector (Landscape)



*backup projector : less than 15kgf

Portrait

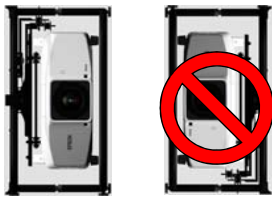

Upper/Under

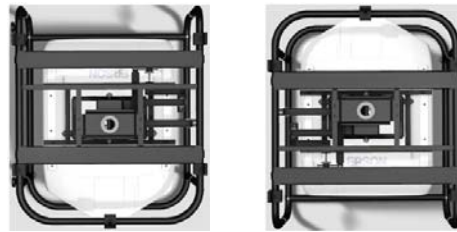

*Place the surface of air filter side to the bottom.
It is according to Finland lens's limitation.
*Foot position should be changed.

*Keep enough space to exhaust the air.

Attention

[Orientation of Lamp]

Finland's limitation is below.

The range of orientation will be restricted to $\pm 5^\circ$ due to the lamp limitation.

The lamp maker cannot assure the use beyond the range.

[Tilt]

[Roll]

[Tilt]

[Roll]

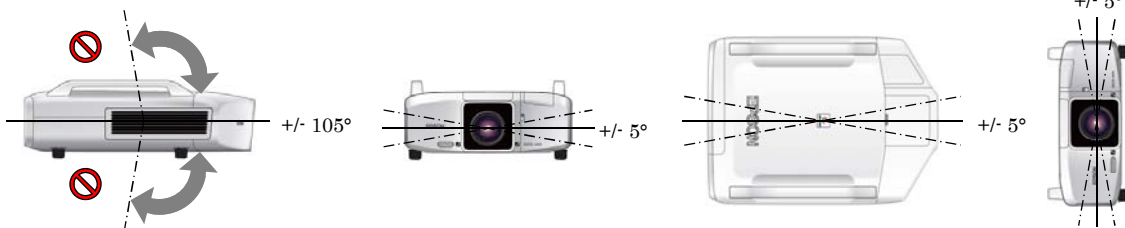

[Polarizer: ELPPL01]

ELPPL01 cannot be attached to this frame directly.

SECTION 01250 - CONTRACT MODIFICATION PROCEDURES

PART 1 - GENERAL

1.1 SUMMARY

- A. This Section specifies administrative and procedural requirements for handling and processing Contract modifications.
- B. See Division 1 Section "Allowances" for procedural requirements for handling and processing allowances.
- C. See Division 1 Section "Unit Prices" for administrative requirements for using unit prices.

1.2 MINOR CHANGES IN THE WORK

- A. Architect will issue supplemental instructions authorizing Minor Changes in the Work, not involving adjustment to the Contract Sum or the Contract Time, on AIA Document G710, "Architect's Supplemental Instructions."

1.3 PROPOSAL REQUESTS

- A. Owner-Initiated Proposal Requests: Architect will issue a detailed description of proposed changes in the Work that may require adjustment to the Contract Sum or the Contract Time. If necessary, the description will include supplemental or revised Drawings and Specifications.
 - 1. Proposal Requests issued by Architect are for information only. Do not consider them instructions either to stop work in progress or to execute the proposed change.
 - 2. Within time specified in Proposal Request after receipt of Proposal Request, submit a quotation estimating cost adjustments to the Contract Sum and the Contract Time necessary to execute the change.
 - a. Include a list of quantities of products required or eliminated and unit costs, with total amount of purchases and credits to be made. If requested, furnish survey data to substantiate quantities.
 - b. Indicate applicable taxes, delivery charges, equipment rental, and amounts of trade discounts.
 - c. Include costs of labor and supervision directly attributable to the change.
 - d. Include an updated Contractor's Construction Schedule that indicates the effect of the change, including, but not limited to, changes in activity duration, start and finish times, and activity relationship. Use available total float before requesting an extension of the Contract Time.

- B. Contractor-Initiated Proposals: If latent or unforeseen conditions require modifications to the Contract, Contractor may propose changes by submitting a request for a change to Architect.
1. Include a statement outlining reasons for the change and the effect of the change on the Work. Provide a complete description of the proposed change. Indicate the effect of the proposed change on the Contract Sum and the Contract Time.
 2. Include a list of quantities of products required or eliminated and unit costs, with total amount of purchases and credits to be made. If requested, furnish survey data to substantiate quantities.
 3. Indicate applicable taxes, delivery charges, equipment rental, and amounts of trade discounts.
 4. Include costs of labor and supervision directly attributable to the change.
 5. Include an updated Contractor's Construction Schedule that indicates the effect of the change, including, but not limited to, changes in activity duration, start and finish times, and activity relationship. Use available total float before requesting an extension of the Contract Time.
 6. Comply with requirements in Division 1 Section "Product Requirements" if the proposed change requires substitution of one product or system for product or system specified.
- C. Proposal Request Form: Use AIA Document G709 for Proposal Requests.

1.4 ALLOWANCES

- A. Allowance Adjustment: To adjust allowance amounts, base each Change Order proposal on the difference between purchase amount and the allowance, multiplied by final measurement of work-in-place. If applicable, include reasonable allowances for cutting losses, tolerances, mixing wastes, normal product imperfections, and similar margins.
1. Include installation costs in purchase amount only where indicated as part of the allowance.
 2. If requested, prepare explanation and documentation to substantiate distribution of overhead costs and other margins claimed.
 3. Submit substantiation of a change in scope of work, if any, claimed in Change Orders related to unit-cost allowances.
 4. Owner reserves the right to establish the quantity of work-in-place by independent quantity survey, measure, or count.
- B. Submit claims for increased costs because of a change in scope or nature of the allowance described in the Contract Documents, whether for the Purchase Order amount or Contractor's handling, labor, installation, overhead, and profit. Submit claims within 21 days of receipt of the Change Order or Construction Change Directive authorizing work to proceed. Owner will reject claims submitted later than 21 days after such authorization.
1. Do not include Contractor's or subcontractor's indirect expense in the Change Order cost amount unless it is clearly shown that the nature or extent of work has

changed from what could have been foreseen from information in the Contract Documents.

2. No change to Contractor's indirect expense is permitted for selection of higher- or lower-priced materials or systems of the same scope and nature as originally indicated.

1.5 CHANGE ORDER PROCEDURES

- A. On Owner's approval of a Proposal Request, Architect will issue a Change Order for signatures of Owner and Contractor on **AIA Document G701**.

1.6 CHANGE DIRECTIVE

- A. Change Directive: Architect may issue a Change Directive. Change Directive instructs Contractor to proceed with a change in the Work, for subsequent inclusion in a Change Order.
 1. Change Directive contains a complete description of change in the Work. It also designates method to be followed to determine change in the Contract Sum or the Contract Time.
- B. Documentation: Maintain detailed records on a time and material basis of work required by the Change Directive.
 1. After completion of change, submit an itemized account and supporting data necessary to substantiate cost and time adjustments to the Contract.

PART 2 - PRODUCTS (Not Used)

PART 3 - EXECUTION (Not Used)

END OF SECTION 01250

SECTION 01290 - PAYMENT PROCEDURES

PART 1 - GENERAL

1.1 SUMMARY

- A. This Section specifies administrative and procedural requirements necessary to prepare and process Applications for Payment.

1.2 SCHEDULE OF VALUES

- A. Coordination: Coordinate preparation of the Schedule of Values with preparation of Contractor's Construction Schedule. Cost-loaded CPM Schedule may serve to satisfy requirements for the Schedule of Values.
 - 1. Correlate line items in the Schedule of Values with other required administrative forms and schedules, including Contractor's Construction Schedule.
 - 2. Submit the Schedule of Values to Architect at earliest possible date but no later than seven days before the date scheduled for submittal of initial Applications for Payment.
 - 3. Sub schedules: Where the Work is separated into phases requiring separately phased payments, provide sub schedules showing values correlated with each phase of payment.
- B. Format and Content: Use the Project Manual table of contents as a guide to establish line items for the Schedule of Values. Provide at least one line item for each Specification Section.
 - 1. Identification: Include the following Project identification on the Schedule of Values:
 - a. Project name and location.
 - b. Name of Architect.
 - c. Architect's project number.
 - d. Contractor's name and address.
 - e. Date of submittal.
 - 2. Submit draft of AIA Document G703 Continuation Sheets
 - 3. Provide a breakdown of the Contract Sum in enough detail to facilitate continued evaluation of Applications for Payment and progress reports. Coordinate with the Project Manual table of contents. Provide several line items for principal subcontract amounts, where appropriate. Include separate line items under required principal subcontracts for operation and maintenance manuals, punch

list activities, Project Record Documents, and demonstration and training in the amount of 5 percent of the Contract Sum.

4. Round amounts to nearest whole dollar; total shall equal the Contract Sum.
5. Provide a separate line item in the Schedule of Values for each part of the Work where Applications for Payment may include materials or equipment purchased or fabricated and stored, but not yet installed.
6. Provide separate line items in the Schedule of Values for initial cost of materials, for each subsequent stage of completion, and for total installed value of that part of the Work.
7. Allowances: Provide a separate line item in the Schedule of Values for each allowance. Show line-item value of unit-cost allowances, as a product of the unit cost, multiplied by measured quantity. Use information indicated in the Contract Documents to determine quantities.
8. Each item in the Schedule of Values and Applications for Payment shall be complete. Include total cost and proportionate share of general overhead and profit for each item.
 - a. Temporary facilities and other major cost items that are not direct cost of actual work-in-place may be shown either as separate line items in the Schedule of Values or distributed as general overhead expense, at Contractor's option.
9. Schedule Updating: Update and resubmit the Schedule of Values before the next Applications for Payment when Change Orders or Construction Change Directives result in a change in the Contract Sum.

1.3 APPLICATIONS FOR PAYMENT

- A. Each Application for Payment shall be consistent with previous applications and payments as certified by Architect and paid for by Owner.
 1. Initial Application for Payment, Application for Payment at time of Substantial Completion, and final Application for Payment involve additional requirements.
- B. Payment Application Times: The date for each progress payment is indicated in the Agreement between Owner and Contractor. The period of construction Work covered by each Application for Payment is the period indicated in the Agreement.
- C. Payment Application Times: Progress payments shall be submitted to Architect by the 5th of the month. The period covered by each Application for Payment is one month, ending on the last day of the month.
- D. Payment Application Forms: Use AIA Document G702 and AIA Document G703 Continuation Sheets as form for Applications for Payment.

- E. Application Preparation: Complete every entry on form. Notarize and execute by a person authorized to sign legal documents on behalf of Contractor. Architect will return incomplete applications without action.
1. Entries shall match data on the Schedule of Values and Contractor's Construction Schedule. Use updated schedules if revisions were made.
 2. Include amounts of Change Orders and Construction Change Directives issued before last day of construction period covered by application.
- F. Transmittal: Submit **3** signed and notarized original copies of each Application for Payment to Architect by a method ensuring receipt. One copy shall include waivers of lien and similar attachments if required.
1. Transmit each copy with a transmittal form listing attachments and recording appropriate information about application.
- G. Waivers of Mechanic's Lien: With each Application for Payment, submit waivers of mechanic's lien from every entity who is lawfully entitled to file a mechanic's lien arising out of the Contract and related to the Work covered by the payment.
1. Submit partial waivers on each item for amount requested in previous application, after deduction for retainage, on each item.
 2. When an application shows completion of an item, submit final or full waivers.
 3. Owner reserves the right to designate which entities involved in the Work must submit waivers.
 4. Waiver Forms: Submit waivers of lien on forms, executed in a manner acceptable to Owner.
- H. Initial Application for Payment: Administrative actions and submittals that must precede or coincide with submittal of first Application for Payment include the following:
1. List of subcontractors.
 2. Schedule of Values.
 3. Contractor's Construction Schedule (preliminary if not final).
 4. Schedule of unit prices.
 5. Submittals Schedule (preliminary if not final).
 6. List of Contractor's staff assignments.
 7. List of Contractor's principal consultants.
 8. Copies of building permits.
 9. Copies of authorizations and licenses from authorities having jurisdiction for performance of the Work.
 10. Initial progress report.
 11. Report of preconstruction conference.
 12. Certificates of insurance and insurance policies.
- I. Application for Payment at Substantial Completion: After issuing the Certificate of Substantial Completion, submit an Application for Payment showing 100 percent completion for portion of the Work claimed as substantially complete.

1. Include documentation supporting claim that the Work is substantially complete and a statement showing an accounting of changes to the Contract Sum.
 2. This application shall reflect Certificates of Partial Substantial Completion issued previously for Owner occupancy of designated portions of the Work.
- J. Final Payment Application: Submit final Application for Payment with releases and supporting documentation not previously submitted and accepted, including, but not limited, to the following:
1. Evidence of completion of Project closeout requirements.
 2. Insurance certificates for products and completed operations where required and proof that taxes, fees, and similar obligations were paid.
 3. Updated final statement, accounting for final changes to the Contract Sum.
 4. AIA Document G706, "Contractor's Affidavit of Payment of Debts and Claims."
 5. AIA Document G706A, "Contractor's Affidavit of Release of Liens."
 6. AIA Document G707, "Consent of Surety to Final Payment."
 7. Evidence that claims have been settled.
 8. Final meter readings for utilities, a measured record of stored fuel, and similar data as of date of Substantial Completion or when Owner took possession of and assumed responsibility for corresponding elements of the Work.
 9. Final, liquidated damages settlement statement.

PART 2 - PRODUCTS (Not Used)

PART 3 - EXECUTION (Not Used)

END OF SECTION 01290

SECTION 01310 - PROJECT MANAGEMENT AND COORDINATION

PART 1 - GENERAL

1.1 SUMMARY

- A. This Section includes administrative provisions for coordinating construction operations on Project including, but not limited to, the following:
 - 1. Coordination Drawings.
 - 2. Project meetings.
- B. See Division 1 Section "Summary of Multiple Contracts" for a description of the division of Work among separate contracts and responsibility for coordination activities not in this Section.
- C. See Division 1 Section "Execution Requirements" for procedures for coordinating general installation and field-engineering services, including establishment of benchmarks and control points.

1.2 COORDINATION

- A. Coordination: Coordinate construction operations included in different Sections of the Specifications to ensure efficient and orderly installation of each part of the Work. Coordinate construction operations, included in different Sections, that depend on each other for proper installation, connection, and operation.
 - 1. Schedule construction operations in sequence required to obtain the best results where installation of one part of the Work depends on installation of other components, before or after its own installation.
 - 2. Coordinate installation of different components with other contractors to ensure maximum accessibility for required maintenance, service, and repair.
 - 3. Make adequate provisions to accommodate items scheduled for later installation.
 - 4. Where availability of space is limited, coordinate installation of different components to ensure maximum performance and accessibility for required maintenance, service, and repair of all components, including mechanical and electrical.
- B. Prepare memoranda for distribution to each party involved, outlining special procedures required for coordination. Include such items as required notices, reports, and list of attendees at meetings.
 - 1. Prepare similar memoranda for Owner and separate contractors if coordination of their Work is required.

- C. Administrative Procedures: Coordinate scheduling and timing of required administrative procedures with other construction activities and activities of other contractors to avoid conflicts and to ensure orderly progress of the Work. Such administrative activities include, but are not limited to, the following:
1. Preparation of Contractor's Construction Schedule.
 2. Preparation of the Schedule of Values.
 3. Installation and removal of temporary facilities and controls.
 4. Delivery and processing of submittals.
 5. Progress meetings.
 6. Preinstallation conferences.
 7. Project closeout activities.
 8. Startup and adjustment of systems.
 9. Project closeout activities.

1.3 SUBMITTALS

- A. Coordination Drawings: Prepare Coordination Drawings if limited space availability necessitates maximum utilization of space for efficient installation of different components or if coordination is required for installation of products and materials fabricated by separate entities.
1. Content: Project-specific information, drawn accurately to scale. Do not base Coordination Drawings on reproductions of the Contract Documents or standard printed data. Include the following information, as applicable:
 - a. Indicate functional and spatial relationships of components of architectural, structural, civil, mechanical, and electrical systems.
 - b. Indicate dimensions shown on the Contract Drawings and make specific note of dimensions that appear to be in conflict with submitted equipment and minimum clearance requirements. Provide alternate sketches to Architect for resolution of such conflicts. Minor dimension changes and difficult installations will not be considered changes to the Contract.
 2. Format: ADOBE PDF.
 3. Provide a fully detailed shop drawing of the intended projector housings including dimensions, access, internal equipment, conduit paths, projector locations, projector access methods and hardware, electrical and data equipment and outlets, and all other misc components. Include all materials to be used in fabrication of the housings and include details of fasteners, securement and connection into the building. Provide final weight data.

1.4 PROJECT MEETINGS

- A. General: Schedule and conduct meetings and conferences at Project site, unless otherwise indicated.

1. Attendees: Inform participants and others involved, and individuals whose presence is required, of date and time of each meeting. Notify Owner and Architect of scheduled meeting dates and times.
 2. Agenda: Prepare the meeting agenda. Distribute the agenda to all invited attendees.
 3. Minutes: Record significant discussions and agreements achieved. Distribute the meeting minutes to everyone concerned, including Owner and Architect, within three days of the meeting.
- B. Preconstruction Conference: Schedule a preconstruction conference before starting construction, at a time convenient to Owner and Architect, but no later than **15** days after execution of the Agreement. Hold the conference at Project site or another convenient location. Conduct the meeting to review responsibilities and personnel assignments.
1. Attendees: Authorized representatives of Owner, Architect, and their consultants; Contractor and its superintendent; major subcontractors; suppliers; and other concerned parties shall attend the conference. All participants at the conference shall be familiar with Project and authorized to conclude matters relating to the Work.
 2. Agenda: Discuss items of significance that could affect progress, including the following:
 - a. Tentative construction schedule.
 - b. Phasing.
 - c. Critical work sequencing and long-lead items.
 - d. Designation of key personnel and their duties.
 - e. Procedures for processing field decisions and Change Orders.
 - f. Procedures for requests for interpretations (RFIs).
 - g. Procedures for testing and inspecting.
 - h. Procedures for processing Applications for Payment.
 - i. Distribution of the Contract Documents.
 - j. Submittal procedures.
 - k. Preparation of Record Documents.
 - l. Use of the premises
 - m. Work restrictions.
 - n. Owner's occupancy requirements.
 - o. Responsibility for temporary facilities and controls.
 - p. Construction waste management and recycling.
 - q. Parking availability.
 - r. Office, work, and storage areas.
 - s. Equipment deliveries and priorities.
 - t. First aid.
 - u. Security.
 - v. Progress cleaning.
 - w. Working hours.

3. Minutes: Record and distribute meeting minutes.
- C. Preinstallation Conferences: Conduct a preinstallation conference at Project site before each construction activity that requires coordination with other construction.
1. Attendees: Installer and representatives of manufacturers and fabricators involved in or affected by the installation and its coordination or integration with other materials and installations that have preceded or will follow, shall attend the meeting. Advise Architect of scheduled meeting dates.
 2. Agenda: Review progress of other construction activities and preparations for the particular activity under consideration, including requirements for the following:
 - a. The Contract Documents.
 - b. Options.
 - c. Related requests for interpretations (RFIs).
 - d. Related Change Orders.
 - e. Purchases.
 - f. Deliveries.
 - g. Submittals.
 - h. Review of mockups.
 - i. Possible conflicts.
 - j. Compatibility problems.
 - k. Time schedules.
 - l. Weather limitations.
 - m. Manufacturer's written recommendations.
 - n. Warranty requirements.
 - o. Compatibility of materials.
 - p. Acceptability of substrates.
 - q. Temporary facilities and controls.
 - r. Space and access limitations.
 - s. Regulations of authorities having jurisdiction.
 - t. Testing and inspecting requirements.
 - u. Installation procedures.
 - v. Coordination with other work.
 - w. Required performance results.
 - x. Protection of adjacent work.
 - y. Protection of construction and personnel.
 3. Record significant conference discussions, agreements, and disagreements, including required corrective measures and actions.
 4. Reporting: Distribute minutes of the meeting to each party present and to parties who should have been present.
 5. Do not proceed with installation if the conference cannot be successfully concluded. Initiate whatever actions are necessary to resolve impediments to performance of the Work and reconvene the conference at earliest feasible date.

- D. Progress Meetings: Conduct progress meetings at weekly intervals. Coordinate dates of meetings with preparation of payment requests.
1. Attendees: In addition to representatives of Owner and Architect, each contractor, subcontractor, supplier, and other entity concerned with current progress or involved in planning, coordination, or performance of future activities shall be represented at these meetings. All participants at the conference shall be familiar with Project and authorized to conclude matters relating to the Work.
 2. Agenda: Review and correct or approve minutes of previous progress meeting. Review other items of significance that could affect progress. Include topics for discussion as appropriate to status of Project.
 - a. Contractor's Construction Schedule: Review progress since the last meeting. Determine whether each activity is on time, ahead of schedule, or behind schedule, in relation to Contractor's Construction Schedule. Determine how construction behind schedule will be expedited; secure commitments from parties involved to do so. Discuss whether schedule revisions are required to ensure that current and subsequent activities will be completed within the Contract Time.
 - 1) Review schedule for next period.
 - b. Review present and future needs of each entity present, including the following:
 - 1) Interface requirements.
 - 2) Sequence of operations.
 - 3) Status of submittals.
 - 4) Deliveries.
 - 5) Off-site fabrication.
 - 6) Access.
 - 7) Site utilization.
 - 8) Temporary facilities and controls.
 - 9) Work hours.
 - 10) Hazards and risks.
 - 11) Progress cleaning.
 - 12) Quality and work standards.
 - 13) Status of correction of deficient items.
 - 14) Field observations.
 - 15) Requests for interpretations (RFIs).
 - 16) Status of proposal requests.
 - 17) Pending changes.
 - 18) Status of Change Orders.
 - 19) Pending claims and disputes.
 - 20) Documentation of information for payment requests.
 3. Minutes: Record the meeting minutes.
 4. Reporting: Distribute minutes of the meeting to each party present and to parties who should have been present.

- a. Schedule Updating: Revise Contractor's Construction Schedule after each progress meeting where revisions to the schedule have been made or recognized. Issue revised schedule concurrently with the report of each meeting.

PART 2 - PRODUCTS (Not Used)

PART 3 - EXECUTION (Not Used)

END OF SECTION 01310

SECTION 01320 - CONSTRUCTION PROGRESS DOCUMENTATION

PART 1 - GENERAL

1.1 SUMMARY

- A. This Section includes administrative and procedural requirements for documenting the progress of construction during performance of the Work, including the following:
 - 1. CONTRACTOR's Construction Schedule
 - 2. Submittals Schedule
 - 3. Daily construction reports
 - 4. Field condition reports
- B. See Division 1 Section "Payment Procedures" for submitting the Schedule of Values.
- C. See Division 1 Section "Photographic Documentation" for submitting construction photographs.

1.2 DEFINITIONS

- A. Activity: A discrete part of a project that can be identified for planning, scheduling, monitoring, and controlling the construction project. Activities included in a construction schedule consume time and resources.
 - 1. Critical activities are activities on the critical path. They must start and finish on the planned early start and finish times.
 - 2. Predecessor Activity: An activity that precedes another activity in the network.
 - 3. Successor Activity: An activity that follows another activity in the network.
- B. CPM: Critical path method, which is a method of planning and scheduling a construction project where activities are arranged based on activity relationships. Network calculations determine when activities can be performed and the critical path of Project.
- C. Critical Path: The longest connected chain of interdependent activities through the network schedule that establishes the minimum overall Project duration and contains no float.
- D. Fragnet: A partial or fragmentary network that breaks down activities into smaller activities for greater detail.
- E. Major Area: A story of construction, a separate building, or a similar significant construction element.

1.3 SUBMITTALS

- A. Submittals Schedule: Submit three copies of schedule. Arrange the following information in a tabular format:
 - 1. Scheduled date for first submittal
 - 2. Specification Section number and title
 - 3. Submittal category (action or informational)
 - 4. Name of subcontractor
 - 5. Description of the Work covered
 - 6. Scheduled date for OWNER's final release or approval by the CONSULTANT
- B. CONTRACTOR's Construction Schedule: Submit two opaque copies of initial schedule, large enough to show entire schedule for entire construction period.
 - 1. Submit an electronic copy of schedule, using software indicated, on CD-R, and labeled to comply with requirements for submittals. Include type of schedule (Initial or Updated) and date on label.

1.4 COORDINATION

- A. Coordinate preparation and processing of schedules and reports with performance of construction activities and with scheduling and reporting of separate contractors.
- B. Coordinate CONTRACTOR's Construction Schedule with the Schedule of Values, list of subcontracts, Submittals Schedule, progress reports, payment requests, and other required schedules and reports.
 - 1. Secure time commitments for performing critical elements of the Work from parties involved.
 - 2. Coordinate each construction activity in the network with other activities and schedule them in proper sequence.

PART 2 - PRODUCTS

2.1 SUBMITTALS SCHEDULE

- A. Preparation: Submit a schedule of submittals, arranged in chronological order by dates required by construction schedule. Include time required for review, resubmittal, ordering, manufacturing, fabrication, and delivery when establishing dates.
 - 1. Coordinate Submittals Schedule with list of subcontracts, the Schedule of Values, and CONTRACTOR's Construction Schedule.
 - 2. Submit concurrently with the first complete submittal of CONTRACTOR's Construction Schedule.

2.2 CONTRACTOR'S CONSTRUCTION SCHEDULE, GENERAL

- A. Time Frame: Extend schedule from date established for the Notice to Proceed to date of Final Completion.
1. Contract completion date shall not be changed by submission of a schedule that shows an early completion date, unless specifically authorized by Change Order.
- B. Activities: Treat each story or separate area as a separate numbered activity for each principal element of the Work. Comply with the following:
1. Activity Duration: Define activities so no activity is longer than 20 days, unless specifically allowed by OWNER.
 2. Procurement Activities: Include procurement process activities for the following long lead items and major items, requiring a cycle of more than 60 days, as separate activities in schedule. Procurement cycle activities include, but are not limited to, submittals, approvals, purchasing, fabrication, and delivery.
 - a. Insert list of major items or pieces of equipment
 3. Submittal Review Time: Include review and resubmittal times indicated in Division 1 Section "Submittal Procedures" in schedule. Coordinate submittal review times in CONTRACTOR's Construction Schedule with Submittals Schedule.
 4. Startup and Testing Time: Include not less than 7 days for startup and testing.
 5. Substantial Completion: Indicate completion in advance of date established for Substantial Completion, and allow time for OWNER/CONSULTANT's administrative procedures necessary for certification of Substantial Completion.
- C. Constraints: Include constraints and work restrictions indicated in the Contract Documents and as follows in schedule, and show how the sequence of the Work is affected.
1. Phasing: Arrange list of activities on schedule by phase.
 2. Work under More Than One Contract: Include a separate activity for each contract.
 3. Work by OWNER: Include a separate activity for each portion of the Work performed by OWNER.
 4. Work Restrictions: Show the effect of the following items on the schedule:
 - a. Coordination with existing construction
 - b. Limitations of continued occupancies
 - c. Uninterruptible services
 - d. Partial occupancy before Substantial Completion
 - e. Use of premises restrictions
 - f. Provisions for future construction
 - g. Seasonal variations
 - h. Environmental control

5. Work Stages: Indicate important stages of construction for each major portion of the Work.
- D. Milestones: Include milestones indicated in the Contract Documents in schedule, including, but not limited to, the Notice to Proceed, Substantial Completion, and Final Completion
 - E. Contract Modifications: For each proposed contract modification and concurrent with its submission, prepare a time-impact analysis using fragnets to demonstrate the effect of the proposed change on the overall project schedule.
- 2.3 CONTRACTOR'S CONSTRUCTION SCHEDULE (GANTT CHART)
- A. Gantt-Chart Schedule: Submit a comprehensive, fully developed, horizontal Gantt-chart-type, CONTRACTOR's Construction Schedule within 15 days of date established for the Notice of Award. Base schedule on the Preliminary Construction Schedule and whatever updating and feedback was received since the start of Project.
 - B. Preparation: Indicate each significant construction activity separately. Identify first workday of each week with a continuous vertical line.
 1. For construction activities that require 3 months or longer to complete, indicate an estimated completion percentage in 10 percent increments within time bar.

PART 3 - EXECUTION

3.1 CONTRACTOR'S CONSTRUCTION SCHEDULE

- A. CONTRACTOR's Construction Schedule Updating: At monthly intervals, update schedule to reflect actual construction progress and activities. Issue schedule before regularly scheduled progress meeting.
 1. Revise schedule immediately after each meeting or other activity where revisions have been recognized or made. Issue updated schedule concurrently with the report of each such meeting.
 2. Include a report with updated schedule that indicates every change, including, but not limited to, changes in logic, durations, actual starts and finishes, and activity durations.
 3. As the Work progresses, indicate Actual Completion percentage for each activity.
- B. Distribution: Distribute copies of approved schedule to OWNER, separate contractors, testing and inspecting agencies, and other parties identified by CONTRACTOR with a need-to-know schedule responsibility.
 1. Post copies in Project meeting rooms and temporary field offices.
 2. When revisions are made, distribute updated schedules to the same parties and post in the same locations. Delete parties from distribution when they have

completed their assigned portion of the Work and are no longer involved in performance of construction activities.

END OF SECTION 01320

SECTION 01322 - PHOTOGRAPHIC DOCUMENTATION

PART 1 - GENERAL

1.1 SUMMARY

- A. This Section includes administrative and procedural requirements for the following:
 - 1. Preconstruction photographs
 - 2. Periodic construction photographs
- B. See Division 1 Section "Closeout Procedures" for submitting digital media as Project Record Documents at Project closeout.
- C. See Division 1 Section "Demonstration and Training" for submitting videotapes of demonstration of equipment and training of OWNER's personnel.

1.2 SUBMITTALS

- A. Key Plan: Submit key plan of Project site and building with notation of vantage points marked for location and direction of each photograph. Indicate elevation or story of construction. Include same label information as corresponding set of photographs.
- B. Construction Photographs: Submit two CDs of each photographic view within seven days of taking photographs.
 - 1. Format: PDF File with 6 photos per page with identifier at bottom of each photo
 - 2. Identification:

1.3 COORDINATION

- A. Auxiliary Services: Cooperate with photographer and provide auxiliary services requested, including access to Project site and use of temporary facilities, including temporary lighting required to produce clear, well-lit photographs without obscuring shadows.

1.4 USAGE RIGHTS

- A. Obtain and transfer copyright usage rights from photographer to OWNER for unlimited reproduction of photographic documentation.

PART 2 - PRODUCTS

PART 3 - EXECUTION

3.1 CONSTRUCTION PHOTOGRAPHS

- A. General: Take photographs using the maximum range of depth of field, and that are in focus, to clearly show the Work. Photographs with blurry or out-of-focus areas will not be accepted.
 - 1. Maintain key plan with each set of construction photographs that identifies each photographic location.
- B. Digital Images: Submit digital images exactly as originally recorded in the digital camera, without alteration, manipulation, editing, or modifications using image-editing software.
 - 1. Date and Time: Include date and time in filename for each image.
 - 2. Field Office Images: Maintain one set of images on CD-ROM in the field office at Project site, available at all times for reference. Identify images same as for those submitted to Architect.
- C. Photographs: Before each phase, take photographs of Project, including existing items to remain during construction. Photographs should show before, during and after images of associated work

END OF SECTION 01322

SECTION 01330 - SUBMITTAL PROCEDURES

PART 1 - GENERAL

1.1 SUMMARY

- A. This Section includes administrative and procedural requirements for submitting Shop Drawings, Product Data, Samples, and other submittals.
- B. See Division 1 Section "Construction Progress Documentation" for submitting schedules and reports, including CONTRACTOR's Construction Schedule.
- C. See Division 1 Section "Photographic Documentation" for submitting construction photographs and construction videotapes.
- D. See Division 1 Section "Quality Requirements" for submitting test and inspection reports and for mockup requirements.
- E. See Division 1 Section "Closeout Procedures" for submitting warranties.
- F. See Division 1 Section "Project Record Documents" for submitting Record Drawings, Record Specifications, and Record Product Data.
- G. See Division 1 Section "Operation and Maintenance Data" for submitting operation and maintenance manuals.
- H. See Division 1 Section "Demonstration and Training" for submitting videotapes of demonstration of equipment and training of OWNER's personnel.

1.2 DEFINITIONS

- A. Action Submittals: Written and graphic information that requires CONSULTANT's responsive action.

1.3 SUBMITTAL PROCEDURES

- A. Coordination: Coordinate preparation and processing of submittals with performance of construction activities.
 - 1. Coordinate each submittal with fabrication, purchasing, testing, delivery, other submittals, and related activities that require sequential activity.
 - 2. Coordinate transmittal of different types of submittals for related parts of the Work so processing will not be delayed because of need to review submittals concurrently for coordination.

- a. OWNER/CONSULTANT reserves the right to withhold action on a submittal requiring coordination with other submittals until related submittals are received.
- B. Submittals Schedule: Comply with requirements in Division 1 Section "Construction Progress Documentation" for list of submittals and time requirements for scheduled performance of related construction activities.
- C. Processing Time: Allow enough time for submittal review, including time for resubmittals, as follows. Time for review shall commence on CONSULTANT's receipt of submittal. No extension of the Contract Time will be authorized because of failure to transmit submittals enough in advance of the Work to permit processing, including resubmittals.
 1. Initial Review: Allow **15** days for initial review of each submittal. Allow additional time if coordination with subsequent submittals is required. CONSULTANT will advise CONTRACTOR when a submittal being processed must be delayed for coordination.
 2. Intermediate Review: If intermediate submittal is necessary, process it in same manner as initial submittal.
 3. Resubmittal Review: Allow 15 days for review of each resubmittal.
- D. Identification: Place a permanent label or title block on each submittal for identification.
 1. Indicate name of firm or entity that prepared each submittal on label or title block.
 2. Provide a space approximately 6 by 8 inches (150 by 200 mm) on label or beside title block to record CONTRACTOR's review.
 3. Include the following information on label for processing and recording action taken:
 - a. Project name
 - b. Date
 - c. Name and address of OWNER
 - d. Name and address of CONSULTANT
 - e. Name and address of CONTRACTOR
 - f. Name and address of subcontractor
 - g. Name and address of supplier
 - h. Name of manufacturer
 - i. Submittal number or other unique identifier, including revision identifier
 - 1) Submittal number shall use Specification Section number followed by a decimal point and then a sequential number (e.g., 06100.01). Resubmittals shall include an alphabetic suffix after another decimal point (e.g., 06100.01.A).
 - j. Number and title of appropriate Specification Section
 - k. Drawing number and detail references, as appropriate
 - l. Location(s) where product is to be installed, as appropriate
 - m. Other necessary identification

- E. Deviations: Highlight, encircle, or otherwise specifically identify deviations from the Contract Documents on submittals.
 - F. Additional Copies: Unless additional copies are required for final submittal, and unless OWNER/CONSULTANT observes noncompliance with provisions in the Contract Documents, initial submittal may serve as final submittal.
 - 1. Additional copies submitted for maintenance manuals will not be marked with action taken and will be returned.
 - G. Transmittal: Include a transmittal and handling. Transmit each submittal using a transmittal form. OWNER will return submittals, without review, received from sources other than CONTRACTOR.
 - H. Resubmittals: Make resubmittals in same form and number of copies as initial submittal.
 - 1. Note date and content of previous submittal.
 - 2. Note date and content of revision in label or title block and clearly indicate extent of revision.
 - 3. Resubmit submittals until they are marked.
 - I. Distribution: Furnish copies of final submittals to manufacturers, subcontractors, suppliers, fabricators, installers, authorities having jurisdiction, and others as necessary for performance of construction activities. Show distribution on transmittal forms.
 - J. Use for Construction: Use only final submittals with mark indicating "Insert approval notation from CONSULTANT's action letter" taken by CONSULTANT.
- 1.4 CONTRACTOR'S USE OF CONSULTANT'S CAD FILES
- A. General: At CONTRACTOR's written request, copies of CONSULTANT's CAD files will be provided to CONTRACTOR for CONTRACTOR's use in connection with Project.

PART 2 - PRODUCTS

2.1 ACTION SUBMITTALS

- A. General: Prepare and submit Action Submittals required by individual Specification Sections.
- B. Product Data: Collect information into a single submittal for each element of construction and type of product or equipment.
 - 1. If information must be specially prepared for submittal because standard printed data are not suitable for use, submit as Shop Drawings, not as Product Data.

2. Mark each copy of each submittal to show which products and options are applicable using ADOBE PDF.
 3. Include the following information, as applicable:
 - a. Manufacturer's written recommendations
 - b. Manufacturer's product specifications
 - c. Manufacturer's installation instructions
 - d. Manufacturer's catalog cuts
 - e. Wiring diagrams showing factory-installed wiring
 - f. Printed performance curves
 - g. Operational range diagrams
 - h. Compliance with specified referenced standards
 - i. Testing by recognized testing agency
 4. Format: All submittals shall be on PDF format only. A single PDF file of each submittal shall be sent to the OWNER representative and copied to the CONSULTANT using a submittal tracking software maintained by the CONTRACTOR. Submittal reviews by CONSULTANT will include a single PDF Letter indicating disposition and actions required by CONTRACTOR. Do not submit hard bound multiple copies of books or drawings. Hard bound submittals will be rejected for improper format. Name the single PDF file as follows – "Sub15050.1-OOC-xxxx", where "15050.1" indicates the specification number where the submittal was required and "xxxx" indicates a brief description of the submittal.
- C. Shop Drawings: Prepare Project-specific information, drawn accurately to scale. Do not base Shop Drawings on reproductions of the Contract Documents or standard printed data.
1. Preparation: Fully illustrate requirements in the Contract Documents. Include the following information, as applicable:
 - a. Dimensions
 - b. Identification of products
 - c. Fabrication and installation drawings
 - d. Roughing-in and setting diagrams
 - e. Wiring diagrams showing field-installed wiring, including power, signal, and control wiring.
 - f. Shopwork manufacturing instructions
 - g. Templates and patterns
 - h. Schedules
 - i. Notation of coordination requirements
 - j. Notation of dimensions established by field measurement
 - k. Relationship to adjoining construction clearly indicated
 - l. Seal and signature of professional Consultant if specified
 - m. Wiring Diagrams: Differentiate between manufacturer-installed and field-installed wiring.
 2. Sheet Size: Except for templates, patterns, and similar full-size drawings, submit Shop Drawings on sheets at least 8-1/2 by 11 inches (215 by 280 mm) but no larger than 30 by 40 inches (750 by 1000 mm).

3. Number of Copies: Submit PDF multi-sheet single file for each shop drawings submittal. See section B above for file naming procedures.
- D. Submittals Schedule: Comply with requirements specified in Division 1 Section "Construction Progress Documentation."
- E. Subcontract List: Prepare a written summary identifying individuals or firms proposed for each portion of the Work, including those who are to furnish products or equipment fabricated to a special design.
 1. Number of Copies: Submit one PDF copy of subcontractor list 3 days prior to pre-construction meeting.

2.2 DELEGATED DESIGN

- A. Performance and Design Criteria: Where professional design services or certifications by a design professional are specifically required of CONTRACTOR by the Contract Documents, provide products and systems complying with specific performance and design criteria indicated.
 1. If criteria indicated are not sufficient to perform services or certification required, submit a written request for additional information to OWNER.
- B. Delegated-Design Submittal: In addition to Shop Drawings, Product Data, and other required submittals, submit **three** copies of a statement, signed and sealed by the responsible design professional, for each product and system specifically assigned to CONTRACTOR to be designed or certified by a design professional.
 1. Indicate that products and systems comply with performance and design criteria in the Contract Documents. Include list of codes, loads, and other factors used in performing these services.

PART 3 - EXECUTION

3.1 CONTRACTOR'S REVIEW

- A. Review each submittal and check for coordination with other Work of the Contract and for compliance with the Contract Documents. Note corrections and field dimensions. Include a CONTRACTOR's approval page before submitting to OWNER.
- B. CONTRACTOR's Approval Page: Provide with each submittal with a separate page created by the Generator Contractor including a typed list of issues and actions required. Include Project name and location, submittal number, Specification Section title and number, name of reviewer, date of CONTRACTOR's approval, and statement certifying that submittal has been reviewed, checked, and approved for compliance with the Contract Documents. A standard sample page shall be submitted for approval prior to 1st submittal.

3.2 CONSULTANT'S ACTION

- A. General: CONSULTANT will not review submittals that do not bear CONTRACTOR's approval stamp and will return them without action.
- B. Action Submittals: CONSULTANT will review each submittal and provide a separate CONSULTANT Submittal Review page. A sample of the review page will be provided during or after pre-construction meeting.
- C. Partial submittals are not acceptable, will be considered nonresponsive, and will be returned without review.
- D. Submittals not required by the Contract Documents may not be reviewed and may be discarded.
- E. Note that O&M Manuals will require a separate hard cover book submittal as identified within section 01782.

END OF SECTION 01330

SECTION 01400 - QUALITY REQUIREMENTS

PART 1 - GENERAL

1.1 SUMMARY

- A. This Section includes administrative and procedural requirements for quality assurance and quality control.
- B. Testing and inspecting services are required to verify compliance with requirements specified or indicated. These services do not relieve Contractor of responsibility for compliance with the Contract Document requirements.
 - 1. Specified tests, inspections, and related actions do not limit Contractor's other quality-assurance and -control procedures that facilitate compliance with the Contract Document requirements.
 - 2. Requirements for Contractor to provide quality-assurance and -control services required by Architect, Owner, or authorities having jurisdiction are not limited by provisions of this Section.
- C. See Divisions 2 through 16 Sections for specific test and inspection requirements.

1.2 DEFINITIONS

- A. Quality-Assurance Services: Activities, actions, and procedures performed before and during execution of the Work to guard against defects and deficiencies and substantiate that proposed construction will comply with requirements.
- B. Quality-Control Services: Tests, inspections, procedures, and related actions during and after execution of the Work to evaluate that actual products incorporated into the Work and completed construction comply with requirements. Services do not include contract enforcement activities performed by Architect.
- C. Mockups: Full-size, physical assemblies that are constructed on-site. Mockups are used to verify selections made under sample submittals, to demonstrate aesthetic effects and, where indicated, qualities of materials and execution, and to review construction, coordination, testing, or operation; they are not Samples.
- D. Preconstruction Testing: Tests and inspections that are performed specifically for the Project before products and materials are incorporated into the Work to verify performance or compliance with specified criteria.
- E. Product Testing: Tests and inspections that are performed by an NRTL, an NVLAP, or a testing agency qualified to conduct product testing and acceptable to authorities

having jurisdiction, to establish product performance and compliance with industry standards.

- F. Source Quality-Control Testing: Tests and inspections that are performed at the source, i.e., plant, mill, factory, or shop.
- G. Field Quality-Control Testing: Tests and inspections that are performed on-site for installation of the Work and for completed Work.
- H. Testing Agency: An entity engaged to perform specific tests, inspections, or both. Testing laboratory shall mean the same as testing agency.
- I. Installer/Applicator/Erector: Contractor or another entity engaged by Contractor as an employee, Subcontractor, or Sub-subcontractor, to perform a particular construction operation, including installation, erection, application, and similar operations.
 - 1. Using a term such as "carpentry" does not imply that certain construction activities must be performed by accredited or unionized individuals of a corresponding generic name, such as "carpenter." It also does not imply that requirements specified apply exclusively to tradespeople of the corresponding generic name.
- J. Experienced: When used with an entity, "experienced" means having successfully completed a minimum of five previous projects similar in size and scope to this Project; being familiar with special requirements indicated; and having complied with requirements of authorities having jurisdiction.
- K. All components and assemblies shall be UL Listed.

1.3 CONFLICTING REQUIREMENTS

- A. General: If compliance with two or more standards is specified and the standards establish different or conflicting requirements for minimum quantities or quality levels, comply with the most stringent requirement. Refer uncertainties and requirements that are different, but apparently equal, to Architect for a decision before proceeding.
- B. Minimum Quantity or Quality Levels: The quantity or quality level shown or specified shall be the minimum provided or performed. The actual installation may comply exactly with the minimum quantity or quality specified, or it may exceed the minimum within reasonable limits. To comply with these requirements, indicated numeric values are minimum or maximum, as appropriate, for the context of requirements. Refer uncertainties to Architect for a decision before proceeding.

1.4 SUBMITTALS

- A. Qualification Data: For testing agencies specified in "Quality Assurance" Article to demonstrate their capabilities and experience. Include proof of qualifications in the

form of a recent report on the inspection of the testing agency by a recognized authority.

- B. Reports: Prepare and submit certified written reports that include the following:
1. Date of issue.
 2. Project title and number.
 3. Name, address, and telephone number of testing agency.
 4. Dates and locations of samples and tests or inspections.
 5. Names of individuals making tests and inspections.
 6. Description of the Work and test and inspection method.
 7. Identification of product and Specification Section.
 8. Complete test or inspection data.
 9. Test and inspection results and an interpretation of test results.
 10. Record of temperature and weather conditions at time of sample taking and testing and inspecting.
 11. Comments or professional opinion on whether tested or inspected Work complies with the Contract Document requirements.
 12. Name and signature of laboratory inspector.
 13. Recommendations on retesting and reinspecting.
- C. Permits, Licenses, and Certificates: For Owner's records, submit copies of permits, licenses, certifications, inspection reports, releases, jurisdictional settlements, notices, receipts for fee payments, judgments, correspondence, records, and similar documents, established for compliance with standards and regulations bearing on performance of the Work.

1.5 QUALITY ASSURANCE

- A. General: Qualifications paragraphs in this Article establish the minimum qualification levels required; individual Specification Sections specify additional requirements.
- B. Installer Qualifications: A firm or individual experienced in installing, erecting, or assembling work similar in material, design, and extent to that indicated for this Project, whose work has resulted in construction with a record of successful in-service performance.
- C. Manufacturer Qualifications: A firm experienced in manufacturing products or systems similar to those indicated for this Project and with a record of successful in-service performance, as well as sufficient production capacity to produce required units.
- D. Fabricator Qualifications: A firm experienced in producing products similar to those indicated for this Project and with a record of successful in-service performance, as well as sufficient production capacity to produce required units.
- E. Professional Engineer Qualifications: A professional engineer who is legally qualified to practice in jurisdiction where Project is located and who is experienced in providing engineering services of the kind indicated. Engineering services are defined as those

performed for installations of the system, assembly, or product that are similar to those indicated for this Project in material, design, and extent.

- F. Specialists: Certain sections of the Specifications require that specific construction activities shall be performed by entities who are recognized experts in those operations. Specialists shall satisfy qualification requirements indicated and shall be engaged for the activities indicated.
 - 1. Requirement for specialists shall not supersede building codes and regulations governing the Work.
- G. Factory-Authorized Service Representative Qualifications: An authorized representative of manufacturer who is trained and approved by manufacturer to inspect installation of manufacturer's products that are similar in material, design, and extent to those indicated for this Project.
- H. Mockups: Before installing portions of the Work requiring mockups, build mockups for each form of construction and finish required to comply with the following requirements, using materials indicated for the completed Work:
 - 1. Build mockups in location and of size indicated or, if not indicated, as directed by Architect.
 - 2. Notify Architect seven days in advance of dates and times when mockups will be constructed.
 - 3. Demonstrate the proposed range of aesthetic effects and workmanship.
 - 4. Obtain Architect's approval of mockups before starting work, fabrication, or construction.
 - 5. Maintain mockups during construction in an undisturbed condition as a standard for judging the completed Work.
 - 6. Demolish and remove mockups when directed, unless otherwise indicated.

1.6 QUALITY CONTROL

- A. Owner Responsibilities: Where quality-control services are indicated as Owner's responsibility, Owner will engage a qualified testing agency to perform these services.
 - 1. Owner will furnish Contractor with names, addresses, and telephone numbers of testing agencies engaged and a description of types of testing and inspecting they are engaged to perform.
 - 2. Costs for retesting and reinspecting construction that replaces or is necessitated by work that failed to comply with the Contract Documents will be charged to Contractor.
- B. Tests and inspections not explicitly assigned to Owner are Contractor's responsibility. Unless otherwise indicated, provide quality-control services specified and those required by authorities having jurisdiction. Perform quality-control services required of Contractor by authorities having jurisdiction, whether specified or not.

1. Where services are indicated as Contractor's responsibility, engage a qualified testing agency to perform these quality-control services.
 - a. Contractor shall not employ same entity engaged by Owner, unless agreed to in writing by Owner.
 2. Notify testing agencies at least 24 hours in advance of time when Work that requires testing or inspecting will be performed.
 3. Where quality-control services are indicated as Contractor's responsibility, submit a certified written report, in duplicate, of each quality-control service.
 4. Testing and inspecting requested by Contractor and not required by the Contract Documents are Contractor's responsibility.
 5. Submit additional copies of each written report directly to authorities having jurisdiction, when they so direct.
- C. **Manufacturer's Field Services:** Where indicated, engage a factory-authorized service representative to inspect field-assembled components and equipment installation, including service connections. Report results in writing as specified in Division 1 Section "Submittal Procedures."
- D. **Retesting/Reinspecting:** Regardless of whether original tests or inspections were Contractor's responsibility, provide quality-control services, including retesting and reinspecting, for construction that replaced Work that failed to comply with the Contract Documents.
- E. **Testing Agency Responsibilities:** Cooperate with Architect and Contractor in performance of duties. Provide qualified personnel to perform required tests and inspections.
1. Notify Architect and Contractor promptly of irregularities or deficiencies observed in the Work during performance of its services.
 2. Determine the location from which test samples will be taken and in which in-situ tests are conducted.
 3. Conduct and interpret tests and inspections and state in each report whether tested and inspected work complies with or deviates from requirements.
 4. Submit a certified written report, in duplicate, of each test, inspection, and similar quality-control service through Contractor.
 5. Do not release, revoke, alter, or increase the Contract Document requirements or approve or accept any portion of the Work.
 6. Do not perform any duties of Contractor.
- F. **Associated Services:** Cooperate with agencies performing required tests, inspections, and similar quality-control services, and provide reasonable auxiliary services as requested. Notify agency sufficiently in advance of operations to permit assignment of personnel. Provide the following:
1. Access to the Work.
 2. Incidental labor and facilities necessary to facilitate tests and inspections.

3. Adequate quantities of representative samples of materials that require testing and inspecting. Assist agency in obtaining samples.
 4. Facilities for storage and field curing of test samples.
 5. Delivery of samples to testing agencies.
 6. Preliminary design mix proposed for use for material mixes that require control by testing agency.
 7. Security and protection for samples and for testing and inspecting equipment at Project site.
- G. Coordination: Coordinate sequence of activities to accommodate required quality-assurance and -control services with a minimum of delay and to avoid necessity of removing and replacing construction to accommodate testing and inspecting.
1. Schedule times for tests, inspections, obtaining samples, and similar activities.

PART 2 - PRODUCTS (Not Used)

PART 3 - EXECUTION

3.1 REPAIR AND PROTECTION

- A. General: On completion of testing, inspecting, sample taking, and similar services, repair damaged construction and restore substrates and finishes.
1. Provide materials and comply with installation requirements specified in other Specification Sections. Restore patched areas and extend restoration into adjoining areas with durable seams that are as invisible as possible.
 2. Comply with the Contract Document requirements for Division 1 Section "Cutting and Patching."
- B. Protect construction exposed by or for quality-control service activities.
- C. Repair and protection are Contractor's responsibility, regardless of the assignment of responsibility for quality-control services.

END OF SECTION 01400

SECTION 01500 - TEMPORARY FACILITIES AND CONTROLS

PART 1 - GENERAL

1.1 SUMMARY

- A. This Section includes requirements for temporary utilities, support facilities, and security and protection facilities.

1.2 DEFINITIONS

- A. Permanent Enclosure: As determined by Consultant, permanent or temporary roofing is complete, insulated, and weather tight; exterior walls are insulated and weather tight; and all openings are closed with permanent construction or substantial temporary closures.

1.3 USE CHARGES

- A. General: Cost or use charges for temporary facilities shall be included in the Contract Sum. Allow other entities to use temporary services and facilities without cost, including, but not limited to, OWNER's construction forces, Consultant, testing agencies, and authorities having jurisdiction.
- B. Water Service: Water from OWNER's existing water system is available for use without metering and without payment of use charges. Provide connections and extensions of services as required for construction operations.
- C. Electric Power Service: Electric power from Owner's existing electrical system is provided. Provide connections and extensions of services as required for construction operations.

1.4 SUBMITTALS

- A. Site Plan: Show temporary facilities, utility hookups, staging areas, and parking areas for construction personnel. A basic layout will be provided during the pre-bid meeting.

1.5 QUALITY ASSURANCE

- A. Electric Service: Comply with NECA, NEMA, and UL standards and regulations for temporary electric service. Install service to comply with NFPA 70.
- B. Tests and Inspections: Arrange for authorities having jurisdiction to test and inspect each temporary utility before use. Obtain required certifications and permits.

1.6 PROJECT CONDITIONS

- A. Temporary Use of Permanent Facilities: Installer of each permanent service shall assume responsibility for operation, maintenance, and protection of each permanent service during its use as a construction facility before OWNER's acceptance, regardless of previously assigned responsibilities.

PART 2 - PRODUCTS

2.1 TEMPORARY FACILITIES

- A. Storage and Fabrication Sheds: Provide sheds sized, furnished, and equipped to accommodate materials and equipment for construction operations as required by contractor.
- B. Note that all staging and storage of materials of construction shall be at contractors risk. An area outside the facility will be provided.

2.2 EQUIPMENT

- A. Fire Extinguishers: Portable, UL rated; with class and extinguishing agent as required by locations and classes of fire exposures.

PART 3 - EXECUTION

3.1 INSTALLATION, GENERAL

- A. Locate facilities where they will serve Project adequately and result in minimum interference with performance of the Work. Relocate and modify facilities as required by progress of the Work.
- B. Provide each facility ready for use when needed to avoid delay. Do not remove until facilities are no longer needed or are replaced by authorized use of completed permanent facilities.

3.2 OPERATION, TERMINATION, AND REMOVAL

- A. Supervision: Enforce strict discipline in use of temporary facilities. To minimize waste and abuse, limit availability of temporary facilities to essential and intended uses.
- B. Maintenance: Maintain facilities in good operating condition until removal.

1. Maintain operation of temporary enclosures, heating, cooling, humidity control, ventilation, and similar facilities on a 24-hour basis where required to achieve indicated results and to avoid possibility of damage.
- C. Temporary Facility Changeover: Do not change over from using temporary security and protection facilities to permanent facilities until Substantial Completion.
- D. Termination and Removal: Remove each temporary facility when need for its service has ended, when it has been replaced by authorized use of a permanent facility, or no later than Substantial Completion. Complete or, if necessary, restore permanent construction that may have been delayed because of interference with temporary facility. Repair damaged Work, clean exposed surfaces, and replace construction that cannot be satisfactorily repaired.
1. Materials and facilities that constitute temporary facilities are property of Contractor. OWNER reserves right to take possession of Project identification signs.
 2. At Substantial Completion, clean and renovate permanent facilities used during construction period. Comply with final cleaning requirements specified in Division 1 Section "Closeout Procedures."

END OF SECTION 01500

SECTION 01600 - PRODUCT REQUIREMENTS

PART 1 - GENERAL

1.1 SUMMARY

- A. This Section includes administrative and procedural requirements for selection of products for use in Project; product delivery, storage, and handling; manufacturers' standard warranties on products; special warranties; product substitutions; and comparable products.
- B. See Division 1 Section "Closeout Procedures" for submitting warranties for Contract closeout.
- C. See Divisions 2 through 16 Sections for specific requirements for warranties on products and installations specified to be warranted.

1.2 DEFINITIONS

- A. Products: Items purchased for incorporating into the Work, whether purchased for Project or taken from previously purchased stock. The term "product" includes the terms "material," "equipment," "system," and terms of similar intent.
 - 1. Named Products: Items identified by manufacturer's product name, including make or model number or other designation shown or listed in manufacturer's published product literature, that is current as of date of the Contract Documents.
 - 2. New Products: Items that have not previously been incorporated into another project or facility. Products salvaged or recycled from other projects are not considered new products.
 - 3. Comparable Product: Product that is demonstrated and approved through submittal process, or where indicated as a product substitution, to have the indicated qualities related to type, function, dimension, in-service performance, physical properties, appearance, and other characteristics that equal or exceed those of specified product.
- B. Substitutions: Changes in products, materials, equipment, and methods of construction from those required by the Contract Documents and proposed by Contractor.
- C. Basis-of-Design Product Specification: Where a specific manufacturer's product is named and accompanied by the words "basis of design," including make or model number or other designation, to establish the significant qualities related to type, function, dimension, in-service performance, physical properties, appearance, and other characteristics for purposes of evaluating comparable products of other named manufacturers.

1.3 SUBMITTALS

- A. Substitution Requests: Submit three copies of each request for consideration. Identify product or fabrication or installation method to be replaced. Include Specification Section number and title and Drawing numbers and titles.
1. Substitution Request Form: Use CSI Form 13.1A.
 2. Documentation: Show compliance with requirements for substitutions and the following, as applicable:
 - a. Statement indicating why specified material or product cannot be provided.
 - b. Coordination information, including a list of changes or modifications needed to other parts of the Work and to construction performed by Owner and separate contractors, that will be necessary to accommodate proposed substitution.
 - c. Detailed comparison of significant qualities of proposed substitution with those of the Work specified. Significant qualities may include attributes such as performance, weight, size, durability, visual effect, and specific features and requirements indicated.
 - d. Product Data, including drawings and descriptions of products and fabrication and installation procedures.
 - e. Samples, where applicable or requested.
 - f. List of similar installations for completed projects with project names and addresses and names and addresses of architects and owners.
 - g. Material test reports from a qualified testing agency indicating and interpreting test results for compliance with requirements indicated.
 - h. Research/evaluation reports evidencing compliance with building code in effect for Project, from a model code organization acceptable to authorities having jurisdiction.
 - i. Detailed comparison of Contractor's Construction Schedule using proposed substitution with products specified for the Work, including effect on the overall Contract Time. If specified product or method of construction cannot be provided within the Contract Time, include letter from manufacturer, on manufacturer's letterhead, stating lack of availability or delays in delivery.
 - j. Cost information, including a proposal of change, if any, in the Contract Sum.
 - k. Contractor's certification that proposed substitution complies with requirements in the Contract Documents and is appropriate for applications indicated.
 - l. Contractor's waiver of rights to additional payment or time that may subsequently become necessary because of failure of proposed substitution to produce indicated results.
 3. Architect's Action: If necessary, Architect will request additional information or documentation for evaluation within **7** days of receipt of a request for substitution. Architect will notify Contractor of acceptance or rejection of proposed substitution within **15** days of receipt of request, or **7** days of receipt of additional information or documentation, whichever is later.

- a. Form of Acceptance: Change Order.
 - b. Use product specified if Architect cannot make a decision on use of a proposed substitution within time allocated.
- B. Comparable Product Requests: Submit three copies of each request for consideration. Identify product or fabrication or installation method to be replaced. Include Specification Section number and title and Drawing numbers and titles.
1. Architect's Action: If necessary, Architect will request additional information or documentation for evaluation within one week of receipt of a comparable product request. Architect will notify Contractor of approval or rejection of proposed comparable product request within **15** days of receipt of request, or **7** days of receipt of additional information or documentation, whichever is later.
 - a. Form of Approval: As specified in Division 1 Section "Submittal Procedures."
 - b. Use product specified if Architect cannot make a decision on use of a comparable product request within time allocated.
- C. Basis-of-Design Product Specification Submittal: Comply with requirements in Division 1 Section "Submittal Procedures." Show compliance with requirements.

1.4 QUALITY ASSURANCE

- A. Compatibility of Options: If Contractor is given option of selecting between two or more products for use on Project, product selected shall be compatible with products previously selected, even if previously selected products were also options.

1.5 PRODUCT DELIVERY, STORAGE, AND HANDLING

- A. Deliver, store, and handle products using means and methods that will prevent damage, deterioration, and loss, including theft. Comply with manufacturer's written instructions.
- B. Delivery and Handling:
1. Schedule delivery to minimize long-term storage at Project site and to prevent overcrowding of construction spaces.
 2. Coordinate delivery with installation time to ensure minimum holding time for items that are flammable, hazardous, easily damaged, or sensitive to deterioration, theft, and other losses.
 3. Deliver products to Project site in an undamaged condition in manufacturer's original sealed container or other packaging system, complete with labels and instructions for handling, storing, unpacking, protecting, and installing.
 4. Inspect products on delivery to ensure compliance with the Contract Documents and to ensure that products are undamaged and properly protected.

C. Storage:

1. Store products to allow for inspection and measurement of quantity or counting of units.
2. Store materials in a manner that will not endanger Project structure.
3. Store products that are subject to damage by the elements, under cover in a weathertight enclosure above ground, with ventilation adequate to prevent condensation.
4. Store cementitious products and materials on elevated platforms.
5. Store foam plastic from exposure to sunlight, except to extent necessary for period of installation and concealment.
6. Comply with product manufacturer's written instructions for temperature, humidity, ventilation, and weather-protection requirements for storage.
7. Protect stored products from damage and liquids from freezing.

1.6 PRODUCT WARRANTIES

- A. Warranties specified in other Sections shall be in addition to, and run concurrent with, other warranties required by the Contract Documents. Manufacturer's disclaimers and limitations on product warranties do not relieve Contractor of obligations under requirements of the Contract Documents.
1. Manufacturer's Warranty: Preprinted written warranty published by individual manufacturer for a particular product and specifically endorsed by manufacturer to Owner.
 2. Special Warranty: Written warranty required by or incorporated into the Contract Documents, either to extend time limit provided by manufacturer's warranty or to provide more rights for Owner.
- B. Special Warranties: Prepare a written document that contains appropriate terms and identification, ready for execution. Submit a draft for approval before final execution.
1. Manufacturer's Standard Form: Modified to include Project-specific information and properly executed.
 2. Specified Form: When specified forms are included with the Specifications, prepare a written document using appropriate form properly executed.
 3. Refer to Divisions 2 through 16 Sections for specific content requirements and particular requirements for submitting special warranties.
- C. Submittal Time: Comply with requirements in Division 1 Section "Closeout Procedures."

PART 2 - PRODUCTS

2.1 PRODUCT SELECTION PROCEDURES

- A. General Product Requirements: Provide products that comply with the Contract Documents, that are undamaged and, unless otherwise indicated, that are new at time of installation.
1. Provide products complete with accessories, trim, finish, fasteners, and other items needed for a complete installation and indicated use and effect.
 2. Standard Products: If available, and unless custom products or nonstandard options are specified, provide standard products of types that have been produced and used successfully in similar situations on other projects.
 3. Owner reserves the right to limit selection to products with warranties not in conflict with requirements of the Contract Documents.
 4. Where products are accompanied by the term "as selected," Architect will make selection.
 5. Where products are accompanied by the term "match sample," sample to be matched is Architect's.
 6. Descriptive, performance, and reference standard requirements in the Specifications establish "salient characteristics" of products.
- B. Product Selection Procedures:
1. Product: Where Specifications name a single product and manufacturer, provide the named product that complies with requirements.
 2. Manufacturer/Source: Where Specifications name a single manufacturer or source, provide a product by the named manufacturer or source that complies with requirements.
 3. Products: Where Specifications include a list of names of both products and manufacturers, provide one of the products listed that complies with requirements.
 4. Manufacturers: Where Specifications include a list of manufacturers' names, provide a product by one of the manufacturers listed that complies with requirements.
 5. Available Products: Where Specifications include a list of names of both products and manufacturers, provide one of the products listed, or an unnamed product, that complies with requirements. Comply with provisions in Part 2 "Comparable Products" Article for consideration of an unnamed product.
 6. Available Manufacturers: Where Specifications include a list of manufacturers, provide a product by one of the manufacturers listed, or an unnamed manufacturer, that complies with requirements. Comply with provisions in Part 2 "Comparable Products" Article for consideration of an unnamed product.
 7. Product Options: Where Specifications indicate that sizes, profiles, and dimensional requirements on Drawings are based on a specific product or system, provide the specified product or system. Comply with provisions in Part 2 "Product Substitutions" Article for consideration of an unnamed product or system.

8. Basis-of-Design Product: Where Specifications name a product and include a list of manufacturers, provide the specified product or a comparable product by one of the other named manufacturers. Drawings and Specifications indicate sizes, profiles, dimensions, and other characteristics that are based on the product named. Comply with provisions in Part 2 "Comparable Products" Article for consideration of an unnamed product by the other named manufacturers.
9. Visual Matching Specification: Where Specifications require matching an established Sample, select a product that complies with requirements and matches Architect's sample. Architect's decision will be final on whether a proposed product matches.
 - a. If no product available within specified category matches and complies with other specified requirements, comply with provisions in Part 2 "Product Substitutions" Article for proposal of product.
10. Visual Selection Specification: Where Specifications include the phrase "as selected from manufacturer's colors, patterns, textures" or a similar phrase, select a product that complies with other specified requirements.
 - a. Standard Range: Where Specifications include the phrase "standard range of colors, patterns, textures" or similar phrase, Architect will select color, pattern, density, or texture from manufacturer's product line that does not include premium items.
 - b. Full Range: Where Specifications include the phrase "full range of colors, patterns, textures" or similar phrase, Architect will select color, pattern, density, or texture from manufacturer's product line that includes both standard and premium items.

2.2 PRODUCT SUBSTITUTIONS

- A. Timing: Architect will consider requests for substitution if received within 3 days after the Notice of Award. Requests received after that time may be considered or rejected at discretion of Architect.
- B. Conditions: Architect will consider Contractor's request for substitution when the following conditions are satisfied. If the following conditions are not satisfied, Architect will return requests without action, except to record noncompliance with these requirements:
 1. Requested substitution offers Owner a substantial advantage in cost, time, energy conservation, or other considerations, after deducting additional responsibilities Owner must assume. Owner's additional responsibilities may include compensation to Architect for redesign and evaluation services, increased cost of other construction by Owner, and similar considerations.
 2. Requested substitution does not require extensive revisions to the Contract Documents.
 3. Requested substitution is consistent with the Contract Documents and will produce indicated results.

4. Substitution request is fully documented and properly submitted.
5. Requested substitution will not adversely affect Contractor's Construction Schedule.
6. Requested substitution has received necessary approvals of authorities having jurisdiction.
7. Requested substitution is compatible with other portions of the Work.
8. Requested substitution has been coordinated with other portions of the Work.
9. Requested substitution provides specified warranty.

2.3 COMPARABLE PRODUCTS

- A. Conditions: Architect will consider Contractor's request for comparable product when the following conditions are satisfied. If the following conditions are not satisfied, Architect will return requests without action, except to record noncompliance with these requirements:
1. Evidence that the proposed product does not require extensive revisions to the Contract Documents, that it is consistent with the Contract Documents and will produce the indicated results, and that it is compatible with other portions of the Work.
 2. Detailed comparison of significant qualities of proposed product with those named in the Specifications. Significant qualities include attributes such as performance, weight, size, durability, visual effect, and specific features and requirements indicated.
 3. Evidence that proposed product provides specified warranty.
 4. List of similar installations for completed projects with project names and addresses and names and addresses of architects and owners, if requested.
 5. Samples, if requested.

PART 3 - EXECUTION (Not Used)

END OF SECTION 01600

SECTION 01700 - EXECUTION REQUIREMENTS

PART 1 - GENERAL

1.1 SUMMARY

- A. This Section includes general procedural requirements governing execution of the Work including, but not limited to, the following:
 - 1. Construction layout.
 - 2. General installation of products.
 - 3. Progress cleaning.
 - 4. Starting and adjusting.
 - 5. Protection of installed construction.
 - 6. Correction of the Work.
- B. See Division 1 Section "Closeout Procedures" for submitting final property survey with Project Record Documents, recording of Owner-accepted deviations from indicated lines and levels, and final cleaning.

PART 2 - PRODUCTS (Not Used)

PART 3 - EXECUTION

3.1 EXAMINATION

- A. Existing Conditions: The existence and location of site improvements, utilities, and other construction indicated as existing are not guaranteed. Before beginning work, investigate and verify the existence and location of mechanical and electrical systems and other construction affecting the Work.
 - 1. Before construction, verify the location and points of connection of utility services.
 - 2. Proceed with installation only after unsatisfactory conditions have been corrected. Proceeding with the Work indicates acceptance of surfaces and conditions.

3.2 PREPARATION

- A. Field Measurements: Take field measurements as required to fit the Work properly. Recheck measurements before installing each product. Where portions of the Work are indicated to fit to other construction, verify dimensions of other construction by field

measurements before fabrication. Coordinate fabrication schedule with construction progress to avoid delaying the Work.

- B. Space Requirements: Verify space requirements and dimensions of items shown diagrammatically on Drawings.
- C. Review of Contract Documents and Field Conditions: Immediately on discovery of the need for clarification of the Contract Documents, submit a request for information to Architect. Include a detailed description of problem encountered, together with recommendations for changing the Contract Documents. Submit requests for interpretation.

3.3 CONSTRUCTION LAYOUT

- A. Verification: Before proceeding to lay out the Work, verify layout information shown on Drawings, in relation to the property survey and existing benchmarks. If discrepancies are discovered, notify Architect promptly.

3.4 INSTALLATION

- A. General: Locate the Work and components of the Work accurately, in correct alignment and elevation, as indicated.
 - 1. Make vertical work plumb and make horizontal work level.
 - 2. Where space is limited, install components to maximize space available for maintenance and ease of removal for replacement.
 - 3. Conceal pipes, ducts, and wiring in finished areas, unless otherwise indicated.
- B. Comply with manufacturer's written instructions and recommendations for installing products in applications indicated.
- C. Install products at the time and under conditions that will ensure the best possible results. Maintain conditions required for product performance until Substantial Completion.
- D. Conduct construction operations so no part of the Work is subjected to damaging operations or loading in excess of that expected during normal conditions of occupancy.
- E. Tools and Equipment: Do not use tools or equipment that produce harmful noise levels.
- F. Templates: Obtain and distribute to the parties involved templates for work specified to be factory prepared and field installed. Check Shop Drawings of other work to confirm that adequate provisions are made for locating and installing products to comply with indicated requirements.

- G. Anchors and Fasteners: Provide anchors and fasteners as required to anchor each component securely in place, accurately located and aligned with other portions of the Work.
 - 1. Mounting Heights: Where mounting heights are not indicated, mount components at heights directed by Architect.
 - 2. Allow for building movement, including thermal expansion and contraction.
 - 3. Coordinate installation of anchorages. Furnish setting drawings, templates, and directions for installing anchorages, including sleeves, concrete inserts, anchor bolts, and items with integral anchors, that are to be embedded in concrete or masonry. Deliver such items to Project site in time for installation.
- H. Joints: Make joints of uniform width. Where joint locations in exposed work are not indicated, arrange joints for the best visual effect. Fit exposed connections together to form hairline joints.
- I. Hazardous Materials: Use products, cleaners, and installation materials that are not considered hazardous.

3.5 PROGRESS CLEANING

- A. General: Clean Project site and work areas daily, including common areas. Coordinate progress cleaning for joint-use areas where more than one installer has worked. Enforce requirements strictly. Dispose of materials lawfully.
 - 1. Comply with requirements in NFPA 241 for removal of combustible waste materials and debris.
 - 2. Do not hold materials more than 7 days during normal weather or 3 days if the temperature is expected to rise above 80 deg F.
 - 3. Containerize hazardous and unsanitary waste materials separately from other waste. Mark containers appropriately and dispose of legally, according to regulations.
- B. Site: Maintain Project site free of waste materials and debris.
- C. Work Areas: Clean areas where work is in progress to the level of cleanliness necessary for proper execution of the Work.
 - 1. Remove liquid spills promptly.
 - 2. Where dust would impair proper execution of the Work, broom-clean or vacuum the entire work area, as appropriate.
- D. Installed Work: Keep installed work clean. Clean installed surfaces according to written instructions of manufacturer or fabricator of product installed, using only cleaning materials specifically recommended. If specific cleaning materials are not recommended, use cleaning materials that are not hazardous to health or property and that will not damage exposed surfaces.

- E. Concealed Spaces: Remove debris from concealed spaces before enclosing the space.
- F. Exposed Surfaces in Finished Areas: Clean exposed surfaces and protect as necessary to ensure freedom from damage and deterioration at time of Substantial Completion.
- G. Waste Disposal: Burying or burning waste materials on-site will not be permitted. Washing waste materials down sewers or into waterways will not be permitted.
- H. During handling and installation, clean and protect construction in progress and adjoining materials already in place. Apply protective covering where required to ensure protection from damage or deterioration at Substantial Completion.
- I. Clean and provide maintenance on completed construction as frequently as necessary through the remainder of the construction period. Adjust and lubricate operable components to ensure operability without damaging effects.
- J. Limiting Exposures: Supervise construction operations to assure that no part of the construction, completed or in progress, is subject to harmful, dangerous, damaging, or otherwise deleterious exposure during the construction period.

3.6 STARTING AND ADJUSTING

- A. Start equipment and operating components to confirm proper operation. Remove malfunctioning units, replace with new units, and retest.
- B. Adjust operating components for proper operation without binding. Adjust equipment for proper operation.
- C. Test each piece of equipment to verify proper operation. Test and adjust controls and safeties. Replace damaged and malfunctioning controls and equipment.
- D. Manufacturer's Field Service: If a factory-authorized service representative is required to inspect field-assembled components and equipment installation, comply with qualification requirements in Division 1 Section "Quality Requirements."
- E. All starting and adjusting of projectors shall be performed by an EPSON certified technician hired by the general contractor.

3.7 PROTECTION OF INSTALLED CONSTRUCTION

- A. Provide final protection and maintain conditions that ensure installed Work is without damage or deterioration at time of Substantial Completion.
- B. Comply with manufacturer's written instructions for temperature and relative humidity.

3.8 CORRECTION OF THE WORK

- A. Repair or remove and replace defective construction. Restore damaged substrates and finishes. Comply with requirements in Division 1 Section "Cutting and Patching."
 - 1. Repairing includes replacing defective parts, refinishing damaged surfaces, touching up with matching materials, and properly adjusting operating equipment.
- B. Restore permanent facilities used during construction to their specified condition.
- C. Remove and replace damaged surfaces that are exposed to view if surfaces cannot be repaired without visible evidence of repair.
- D. Repair components that do not operate properly. Remove and replace operating components that cannot be repaired.
- E. Remove and replace chipped, scratched, and broken glass or reflective surfaces.

END OF SECTION 01700

SECTION 01731 - CUTTING AND PATCHING

PART 1 - GENERAL

1.1 SUMMARY

- A. This Section includes procedural requirements for cutting and patching.
- B. See Divisions 2 through 16 Sections for specific requirements and limitations applicable to cutting and patching individual parts of the Work.
- C. See Division 7 Section "Through-Penetration Fire stop Systems" for patching fire-rated construction.

1.2 SUBMITTALS

- A. Cutting and Patching Proposal: Submit a proposal describing procedures at least 10 days before the time cutting and patching will be performed, requesting approval to proceed. Include the following information:
 - 1. Extent: Describe cutting and patching, show how they will be performed, and indicate why they cannot be avoided.
 - 2. Changes to In-Place Construction: Describe anticipated results. Include changes to structural elements and operating components as well as changes in building's appearance and other significant visual elements.
 - 3. Products: List products to be used and firms or entities that will perform the Work.
 - 4. Dates: Indicate when cutting and patching will be performed.
 - 5. Utility Services and Mechanical/Electrical Systems: List services/systems that cutting and patching procedures will disturb or affect. List services/systems that will be relocated and those that will be temporarily out of service. Indicate how long services/systems will be disrupted.
 - 6. Structural Elements: Where cutting and patching involve adding reinforcement to structural elements, submit details and engineering calculations showing integration of reinforcement with original structure.
 - 7. CONSULTANT's Approval: Obtain approval of cutting and patching proposal before cutting and patching. Approval does not waive right to later require removal and replacement of unsatisfactory work.

1.3 QUALITY ASSURANCE

- A. Structural Elements: Do not cut and patch structural elements in a manner that could change their load-carrying capacity or load-deflection ratio.

1. Insert list of elements that might otherwise be overlooked as structural elements and that require CONSULTANT's approval of a cutting and patching proposal.
- B. Operational Elements: Do not cut and patch operating elements and related components in a manner that results in reducing their capacity to perform as intended or that results in increased maintenance or decreased operational life or safety.
- C. Miscellaneous Elements: Do not cut and patch miscellaneous elements or related components in a manner that could change their load-carrying capacity, that results in reducing their capacity to perform as intended, or that results in increased maintenance or decreased operational life or safety.
- D. Visual Requirements: Do not cut and patch construction in a manner that results in visual evidence of cutting and patching. Do not cut and patch construction exposed on the exterior or in occupied spaces in a manner that would, in CONSULTANT's opinion, reduce the building's aesthetic qualities. Remove and replace construction that has been cut and patched in a visually unsatisfactory manner.

1.4 WARRANTY

- A. Existing Warranties: Remove, replace, patch, and repair materials and surfaces cut or damaged during cutting and patching operations, by methods and with materials so as not to void existing warranties.

PART 2 - PRODUCTS

2.1 MATERIALS

- A. General: Comply with requirements specified in other Sections.
- B. In-Place Materials: Use materials identical to in-place materials. For exposed surfaces, use materials that visually match in-place adjacent surfaces to the fullest extent possible.
 1. If identical materials are unavailable or cannot be used, use materials that, when installed, will match the visual and functional performance of in-place materials.

PART 3 - EXECUTION

3.1 EXAMINATION

- A. Examine surfaces to be cut and patched and conditions under which cutting and patching are to be performed.

1. Compatibility: Before patching, verify compatibility with and suitability of substrates, including compatibility with in-place finishes or primers.
2. Proceed with installation only after unsafe or unsatisfactory conditions have been corrected.

3.2 PREPARATION

- A. Temporary Support: Provide temporary support of Work to be cut.
- B. Protection: Protect in-place construction during cutting and patching to prevent damage. Provide protection from adverse weather conditions for portions of Project that might be exposed during cutting and patching operations.
- C. Adjoining Areas: Avoid interference with use of adjoining areas or interruption of free passage to adjoining areas.
- D. Existing Utility Services and Mechanical/Electrical Systems: Where existing services/systems are required to be removed, relocated, or abandoned, bypass such services/systems before cutting to prevent interruption to occupied areas.

3.3 PERFORMANCE

- A. General: Employ skilled workers to perform cutting and patching. Proceed with cutting and patching at the earliest feasible time, and complete without delay.
 1. Cut in-place construction to provide for installation of other components or performance of other construction, and subsequently patch as required to restore surfaces to their original condition.
- B. Cutting: Cut in-place construction by sawing, drilling, breaking, chipping, grinding, and similar operations, including excavation, using methods least likely to damage elements retained or adjoining construction. If possible, review proposed procedures with original Installer; comply with original Installer's written recommendations.
 1. In general, use hand or small power tools designed for sawing and grinding, not hammering and chopping. Cut holes and slots as small as possible, neatly to size required, and with minimum disturbance of adjacent surfaces. Temporarily cover openings when not in use.
 2. Finished Surfaces: Cut or drill from the exposed or finished side into concealed surfaces.
 3. Concrete/Masonry: Cut using a cutting machine, such as an abrasive saw or a diamond-core drill.
 4. Excavating and Backfilling: Comply with requirements in applicable Division 2 Sections where required by cutting and patching operations.
 5. Mechanical and Electrical Services: Cut off pipe or conduit in walls or partitions to be removed. Cap, valve, or plug and seal remaining portion of pipe or conduit to prevent entrance of moisture or other foreign matter after cutting.

6. Proceed with patching after construction operations requiring cutting are complete.
- C. Patching: Patch construction by filling, repairing, refinishing, closing up, and similar operations following performance of other Work. Patch with durable seams that are as invisible as possible. Provide materials and comply with installation requirements specified in other Sections.
1. Inspection: Where feasible, test and inspect patched areas after completion to demonstrate integrity of installation.
 2. Exposed Finishes: Restore exposed finishes of patched areas and extend finish restoration into retained adjoining construction in a manner that will eliminate evidence of patching and refinishing.
 3. Floors and Walls: Where walls or partitions that are removed extend one finished area into another, patch and repair floor and wall surfaces in the new space. Provide an even surface of uniform finish, color, texture, and appearance. Remove in-place floor and wall coverings and replace with new materials, if necessary, to achieve uniform color and appearance.
 4. Ceilings: Patch, repair, or re-hang in-place ceilings as necessary to provide an even-plane surface of uniform appearance.
 5. Exterior Building Enclosure: Patch components in a manner that restores enclosure to a weather tight condition.
- D. Cleaning: Clean areas and spaces where cutting and patching are performed. Completely remove paint, mortar, oils, putty, and similar materials.

END OF SECTION 01731

SECTION 01770 - CLOSEOUT PROCEDURES

PART 1 - GENERAL

1.1 SUMMARY

- A. This Section includes administrative and procedural requirements for contract closeout, including, but not limited to, the following:
 - 1. Inspection procedures
 - 2. Warranties
 - 3. Final cleaning
- B. See Division 1 Section "Photographic Documentation" for submitting Final Completion construction photographs and negatives.
- C. See Division 1 Section "Operation and Maintenance Data" for operation and maintenance manual requirements.
- D. See Division 1 Section "Demonstration and Training" for requirements for instructing OWNER's personnel.

1.2 SUBSTANTIAL COMPLETION

- A. Preliminary Procedures: Before requesting inspection for determining date of Substantial Completion, complete the following. List items below that are incomplete in request.
 - 1. Prepare a list of items to be completed and corrected (punch list), the value of items on the list, and reasons why the Work is not complete.
 - 2. Advise OWNER of pending insurance changeover requirements.
 - 3. Submit specific warranties, workmanship bonds, maintenance service agreements, final certifications, and similar documents.
 - 4. Obtain and submit releases permitting OWNER unrestricted use of the Work and access to services and utilities. Include occupancy permits, operating certificates, and similar releases.
 - 5. Prepare and submit Project Record Documents, operation and maintenance manuals, Final Completion construction photographs, damage or settlement surveys, property surveys, and similar final record information.
 - 6. Deliver tools, spare parts, extra materials, and similar items to location designated by OWNER. Label with manufacturer's name and model number where applicable.
 - 7. Make final changeover of permanent locks and deliver keys to OWNER. Advise OWNER's personnel of changeover in security provisions.
 - 8. Complete startup testing of systems.

9. Submit test/adjust/balance records.
 10. Terminate and remove temporary facilities from Project site, along with mockups, construction tools, and similar elements.
 11. Advise OWNER of changeover in heat and other utilities.
 12. Submit changeover information related to OWNER's occupancy, use, operation, and maintenance.
 13. Complete final cleaning requirements, including touchup painting.
 14. Touch up and otherwise repair and restore marred exposed finishes to eliminate visual defects.
- B. Inspection: Submit a written request for inspection for Substantial Completion. On receipt of request, OWNER and CONSULTANT will either proceed with inspection or notify CONTRACTOR of unfulfilled requirements. CONSULTANT will prepare the Certificate of Substantial Completion after inspection or will notify CONTRACTOR of items, either on CONTRACTOR's list or additional items identified by CONSULTANT, that must be completed or corrected before certificate will be issued.
1. Re-inspection: Request re-inspection when the Work identified in previous inspections as incomplete is completed or corrected.
 2. Results of completed inspection will form the basis of requirements for Final Completion.

1.3 FINAL COMPLETION

- A. Preliminary Procedures: Before requesting final inspection for determining date of Final Completion, complete the following:
1. Submit a final Application for Payment according to Division 1 Section "Payment Procedures."
 2. Submit certified copy of CONSULTANT's Substantial Completion inspection list of items to be completed or corrected (punch list), endorsed and dated by CONSULTANT. The certified copy of the list shall state that each item has been completed or otherwise resolved for acceptance.
 3. Submit evidence of final, continuing insurance coverage complying with insurance requirements.
 4. Submit pest-control final inspection report and warranty.
 5. Instruct OWNER's personnel in operation, adjustment, and maintenance of products, equipment, and systems. Submit demonstration and training videotapes.
- B. Inspection: Submit a written request for final inspection for acceptance. On receipt of request, CONSULTANT will either proceed with inspection or notify CONTRACTOR of unfulfilled requirements. CONSULTANT will prepare a final Certificate for Payment after inspection or will notify CONTRACTOR of construction that must be completed or corrected before certificate will be issued.
1. Reinspection: Request reinspection when the Work identified in previous inspections as incomplete is completed or corrected.

1.4 LIST OF INCOMPLETE ITEMS (PUNCH LIST)

- A. Preparation: Submit three copies of list. Include name and identification of each space and area affected by construction operations for incomplete items and items needing correction including, if necessary, areas disturbed by CONTRACTOR that are outside the limits of construction. Use CSI Form 14.1A.
1. Organize list of spaces in sequential order,
 2. Organize items applying to each space by major element, including categories for ceiling, individual walls, floors, equipment, and building systems.

1.5 WARRANTIES

- A. Submittal Time: Submit written warranties on request of CONSULTANT for designated portions of the Work where commencement of warranties other than date of Substantial Completion is indicated.
- B. Organize warranty documents into an orderly sequence based on the table of contents of the Project Manual.
1. Bind warranties and bonds in heavy-duty, 3-ring, vinyl-covered, loose-leaf binders, thickness as necessary to accommodate contents, and sized to receive 8-1/2-by-11-inch (215-by-280-mm) paper.
 2. Provide heavy paper dividers with plastic-covered tabs for each separate warranty. Mark tab to identify the product or installation. Provide a typed description of the product or installation, including the name of the product and the name, address, and telephone number of Installer.
 3. Identify each binder on the front and spine with the typed or printed title "WARRANTIES," Project name, and name of CONTRACTOR.
- C. Provide additional copies of each warranty to include in operation and maintenance manuals.

PART 2 - PRODUCTS

2.1 MATERIALS

- A. Cleaning Agents: Use cleaning materials and agents recommended by manufacturer or fabricator of the surface to be cleaned. Do not use cleaning agents that are potentially hazardous to health or property or that might damage finished surfaces.

PART 3 - EXECUTION

3.1 FINAL CLEANING

- A. General: Provide final cleaning. Conduct cleaning and waste-removal operations to comply with local laws and ordinances and Federal and local environmental and antipollution regulations.
- B. Cleaning: Employ experienced workers or professional cleaners for final cleaning. Clean each surface or unit to condition expected in an average commercial building cleaning and maintenance program. Comply with manufacturer's written instructions.
 - 1. Complete the following cleaning operations before requesting inspection for certification of Substantial Completion for entire Project or for a portion of Project:
 - a. Clean Project site, yard, and grounds, in areas disturbed by construction activities, including landscape development areas, of rubbish, waste material, litter, and other foreign substances.
 - b. Sweep paved areas broom clean. Remove petrochemical spills, stains, and other foreign deposits.
 - c. Rake grounds that are neither planted nor paved to a smooth, even-textured surface.
 - d. Remove tools, construction equipment, machinery, and surplus material from Project site.
 - e. Remove snow and ice to provide safe access to building.
 - f. Clean exposed exterior and interior hard-surfaced finishes to a dirt-free condition, free of stains, films, and similar foreign substances. Avoid disturbing natural weathering of exterior surfaces. Restore reflective surfaces to their original condition.
 - g. Remove debris and surface dust from limited access spaces, including roofs, plenums, shafts, trenches, equipment vaults, manholes, attics, and similar spaces.
 - h. Sweep concrete floors broom clean in unoccupied spaces.
 - i. Vacuum carpet and similar soft surfaces, removing debris and excess nap; shampoo if visible soil or stains remain.
 - j. Clean transparent materials, including mirrors and glass in doors and windows. Remove glazing compounds and other noticeable, vision-obscuring materials. Replace chipped or broken glass and other damaged transparent materials. Polish mirrors and glass, taking care not to scratch surfaces.
 - k. Remove labels that are not permanent.
 - l. Touch up and otherwise repair and restore marred, exposed finishes and surfaces. Replace finishes and surfaces that cannot be satisfactorily repaired or restored or that already show evidence of repair or restoration.
 - 1) Do not paint over "UL" and similar labels, including mechanical and electrical nameplates.

- m. Wipe surfaces of mechanical and electrical equipment, and similar equipment. Remove excess lubrication, paint and mortar droppings, and other foreign substances.
 - n. Replace parts subject to unusual operating conditions.
 - o. Clean plumbing fixtures to a sanitary condition, free of stains, including stains resulting from water exposure.
 - p. Replace disposable air filters and clean permanent air filters. Clean exposed surfaces of diffusers, registers, and grills.
 - q. Clean light fixtures, lamps, globes, and reflectors to function with full efficiency. Replace burned-out bulbs, and those noticeably dimmed by hours of use, and defective and noisy starters in fluorescent and mercury vapor fixtures to comply with requirements for new fixtures.
 - r. Leave Project clean and ready for occupancy.
- C. Pest Control: Engage an experienced, licensed exterminator to make a final inspection and rid Project of rodents, insects, and other pests. Prepare a report.
- D. Comply with safety standards for cleaning. Do not burn waste materials. Do not bury debris or excess materials on OWNER's property. Do not discharge volatile, harmful, or dangerous materials into drainage systems. Remove waste materials from Project site and dispose of lawfully.

END OF SECTION 01770

SECTION 01781 - PROJECT RECORD DOCUMENTS

PART 1 - GENERAL

1.1 SUMMARY

- A. This Section includes administrative and procedural requirements for Project Record Documents, including the following:
 - 1. Record Drawings
 - 2. Record Specifications
 - 3. Record Product Data
- B. See Division 1 Section "Operation and Maintenance Data" for operation and maintenance manual requirements.
- C. See Divisions 2 through 16 Sections for specific requirements for Project Record Documents of the Work in those Sections.

1.2 SUBMITTALS

- A. Record Drawings: Comply with the following:
 - 1. Number of Copies: Submit one set(s) of marked-up Record Prints.
 - 2. Number of Copies: Submit copies of Record Drawings as follows:
 - a. Initial Submittal: Submit one set(s) of corrected Record Transparencies and one set(s) of marked-up Record Prints. Consultant will initial and date each plot and mark whether general scope of changes, additional information recorded, and quality of drafting are acceptable. Consultant will return plot and prints for organizing into sets, printing, binding, and final submittal.
 - b. Final Submittal: Submit one set(s) of marked-up Record Prints, and the following:
 - 1) Record CAD Drawing Files and Plots: two set(s).
- B. Record Specifications: Submit one copy of Project's Specifications, including addenda and contract modifications.
- C. Record Product Data: Submit one copy of each Product Data submittal.

PART 2 - PRODUCTS

2.1 RECORD DRAWINGS

- A. Record Prints: Maintain one set of blue- or black-line white prints of the Contract Drawings and Shop Drawings.
1. Preparation: Mark Record Prints to show the actual installation where installation varies from that shown originally. Require individual or entity who obtained record data, whether individual or entity is Installer, subcontractor, or similar entity, to prepare the marked-up Record Prints.
 - a. Give particular attention to information on concealed elements that would be difficult to identify or measure and record later.
 - b. Record data as soon as possible after obtaining it. Record and check the markup before enclosing concealed installations.
 2. Mark the Contract Drawings or Shop Drawings, whichever is most capable of showing actual physical conditions, completely and accurately. If Shop Drawings are marked, show cross-reference on the Contract Drawings.
 3. Mark record sets with erasable, red-colored pencil. Use other colors to distinguish between changes for different categories of the Work at same location.
 4. Note Construction Change Directive numbers, alternate numbers, Change Order numbers, and similar identification, where applicable.
- B. Format: Identify and date each Record Drawing; include the designation "PROJECT RECORD DRAWING" in a prominent location.
1. Record Prints: Organize Record Prints and newly prepared Record Drawings into manageable sets. Bind each set with durable paper cover sheets. Include identification on cover sheets.
 2. Record Transparencies: Organize into unbound sets matching Record Prints. Place transparencies in durable tube-type drawing containers with end caps. Mark end cap of each container with identification. If container does not include a complete set, identify Drawings included.
 3. Record CAD Drawings: Organize CAD information into separate electronic files that correspond to each sheet of the Contract Drawings. Name each file with the sheet identification. Include identification in each CAD file.
 4. Identification: As follows:
 - a. Project name
 - b. Date
 - c. Designation "PROJECT RECORD DRAWINGS"
 - d. Name of Consultant
 - e. Name of Contractor

2.2 RECORD SPECIFICATIONS

- A. Preparation: Mark Specifications to indicate the actual product installation where installation varies from that indicated in Specifications, addenda, and contract modifications.
1. Give particular attention to information on concealed products and installations that cannot be readily identified and recorded later.
 2. Mark copy with the proprietary name and model number of products, materials, and equipment furnished, including substitutions and product options selected.
 3. Record the name of manufacturer, supplier, Installer, and other information necessary to provide a record of selections made.
 4. Note related Change Orders, Record Product Data, and Record Drawings where applicable.

2.3 RECORD PRODUCT DATA

- A. Preparation: Mark Product Data to indicate the actual product installation where installation varies substantially from that indicated in Product Data submittal.
1. Give particular attention to information on concealed products and installations that cannot be readily identified and recorded later.
 2. Include significant changes in the product delivered to Project site and changes in manufacturer's written instructions for installation.
 3. Note related Change Orders, Record Specifications, and Record Drawings where applicable.

PART 3 - EXECUTION

3.1 RECORDING AND MAINTENANCE

- A. Recording: Maintain one copy of each submittal during the construction period for Project Record Document purposes. Post changes and modifications to Project Record Documents as they occur; do not wait until the end of Project.
- B. Maintenance of Record Documents and Samples: Store Record Documents and Samples in the field office apart from the Contract Documents used for construction. Do not use Project Record Documents for construction purposes. Maintain Record Documents in good order and in a clean, dry, legible condition, protected from deterioration and loss. Provide access to Project Record Documents for Consultant's reference during normal working hours.

END OF SECTION 01781

SECTION 01782 - OPERATION AND MAINTENANCE DATA

PART 1 - GENERAL

1.1 SUMMARY

- A. This Section includes administrative and procedural requirements for preparing operation and maintenance manuals, including the following:
 - 1. Operation manuals for systems, subsystems, and equipment.
 - 2. Maintenance manuals for the care and maintenance of systems and equipment.
- B. See Divisions 2 through 16 Sections for specific operation and maintenance manual requirements for the Work in those Sections.

1.2 SUBMITTALS

- A. Manual: Submit two copies of each manual in final form at least 15 days before final inspection.

PART 2 - PRODUCTS

2.1 MANUALS, GENERAL

- A. Organization: Unless otherwise indicated, organize each manual into a separate section for each system and subsystem, and a separate section for each piece of equipment not part of a system. Each manual shall contain a title page, table of contents, and manual contents.
- B. Title Page: Enclose title page in transparent plastic sleeve. Include the following information:
 - 1. Subject matter included in manual.
 - 2. Name and address of Project.
 - 3. Name and address of OWNER.
 - 4. Date of submittal.
 - 5. Name, address, and telephone number of Contractor.
 - 6. Name and address of Architect.
 - 7. Cross-reference to related systems in other operation and maintenance manuals.
- C. Table of Contents: List each product included in manual, identified by product name, indexed to the content of the volume, and cross-referenced to Specification Section number in Project Manual.

- D. Manual Contents: Organize into sets of manageable size. Arrange contents alphabetically by system, subsystem, and equipment. If possible, assemble instructions for subsystems, equipment, and components of one system into a single binder.
1. Binders: Heavy-duty, 3-ring, vinyl-covered, loose-leaf binders, in thickness necessary to accommodate contents, sized to hold 8-1/2-by-11-inch (215-by-280-mm) paper; with clear plastic sleeve on spine to hold label describing contents and with pockets inside covers to hold folded oversize sheets.
 - a. Identify each binder on front and spine, with printed title "OPERATION AND MAINTENANCE MANUAL," Project title or name, and subject matter of contents. Indicate volume number for multiple-volume sets.
 2. Dividers: Heavy-paper dividers with plastic-covered tabs for each section. Mark each tab to indicate contents. Include typed list of products and major components of equipment included in the section on each divider, cross-referenced to Specification Section number and title of Project Manual.
 3. Protective Plastic Sleeves: Transparent plastic sleeves designed to enclose diagnostic software diskettes for computerized electronic equipment.
 4. Drawings: Attach reinforced, punched binder tabs on drawings and bind with text.
 - a. If oversize drawings are necessary, fold drawings to same size as text pages and use as foldouts.
 - b. If drawings are too large to be used as foldouts, fold and place drawings in labeled envelopes and bind envelopes in rear of manual. At appropriate locations in manual, insert typewritten pages indicating drawing titles, descriptions of contents, and drawing locations.

2.2 OPERATION MANUALS

- A. Content: In addition to requirements in this Section, include operation data required in individual Specification Sections and equipment descriptions, operating standards, operating procedures, operating logs, wiring and control diagrams, and license requirements.
- B. Descriptions: Include the following:
1. Product name and model number
 2. Manufacturer's name
 3. Equipment identification with serial number of each component
 4. Equipment function
 5. Operating characteristics
 6. Limiting conditions
 7. Performance curves
 8. Engineering data and tests
 9. Complete nomenclature and number of replacement parts

- C. Operating Procedures: Include start-up, break-in, and control procedures; stopping and normal shutdown instructions; routine, normal, seasonal, and weekend operating instructions; and required sequences for electric or electronic systems.
- D. Systems and Equipment Controls: Describe the sequence of operation, and diagram controls as installed.
- E. Piped Systems: Diagram piping as installed, and identify color-coding where required for identification.

2.3 SYSTEMS AND EQUIPMENT MAINTENANCE MANUAL

- A. Content: For each system, subsystem, and piece of equipment not part of a system, include source information, manufacturers' maintenance documentation, maintenance procedures, maintenance and service schedules, spare parts list and source information, maintenance service contracts, and warranty and bond information, as described below.
- B. Source Information: List each system, subsystem, and piece of equipment included in manual, identified by product name and arranged to match manual's table of contents. For each product, list name, address, and telephone number of Installer or supplier and maintenance service agent, and cross-reference Specification Section number and title in Project Manual.
- C. Manufacturers' Maintenance Documentation: Manufacturers' maintenance documentation including maintenance instructions, drawings and diagrams for maintenance, nomenclature of parts and components, and recommended spare parts for each component part or piece of equipment:
- D. Maintenance Procedures: Include test and inspection instructions, troubleshooting guide, disassembly instructions, and adjusting instructions, and demonstration and training videotape if available, that detail essential maintenance procedures:
- E. Maintenance and Service Schedules: Include service and lubrication requirements, list of required lubricants for equipment, and separate schedules for preventive and routine maintenance and service with standard time allotment.
- F. Spare Parts List and Source Information: Include lists of replacement and repair parts, with parts identified and cross-referenced to manufacturers' maintenance documentation and local sources of maintenance materials and related services.
- G. Maintenance Service Contracts: Include copies of maintenance agreements with name and telephone number of service agent.
- H. Warranties and Bonds: Include copies of warranties and bonds and lists of circumstances and conditions that would affect validity of warranties or bonds.

PART 3 - EXECUTION

3.1 MANUAL PREPARATION

- A. Emergency Manual: Assemble a complete set of emergency information indicating procedures for use by emergency personnel and by OWNER's operating personnel for types of emergencies indicated.
- B. Product Maintenance Manual: Assemble a complete set of maintenance data indicating care and maintenance of each product, material, and finish incorporated into the Work.
- C. Operation and Maintenance Manuals: Assemble a complete set of operation and maintenance data indicating operation and maintenance of each system, subsystem, and piece of equipment not part of a system.
- D. Manufacturers' Data: Where manuals contain manufacturers' standard printed data, include only sheets pertinent to product or component installed. Mark each sheet to identify each product or component incorporated into the Work. If data include more than one item in a tabular format, identify each item using appropriate references from the Contract Documents. Identify data applicable to the Work and delete references to information not applicable.
- E. Drawings: Prepare drawings supplementing manufacturers' printed data to illustrate the relationship of component parts of equipment and systems and to illustrate control sequence and flow diagrams. Coordinate these drawings with information contained in Record Drawings to ensure correct illustration of completed installation.
 - 1. Do not use original Project Record Documents as part of operation and maintenance manuals.
- F. Comply with Division 1 Section "Closeout Procedures" for schedule for submitting operation and maintenance documentation.

END OF SECTION 01782

SECTION 01820 - DEMONSTRATION AND TRAINING

PART 1 - GENERAL

1.1 SUMMARY

- A. This Section includes administrative and procedural requirements for instructing OWNER's personnel, including the following:
 - 1. Demonstration of operation of systems, subsystems, and equipment.
 - 2. Training in operation and maintenance of systems, subsystems, and equipment.
 - 3. Demonstration and training videotapes.
- B. See Divisions 2 through 16 Sections for specific requirements for demonstration and training for products in those Sections.

1.2 SUBMITTALS

- A. Instruction Program: Submit two copies of outline of instructional program for demonstration and training, including a schedule of proposed dates, times, length of instruction time, and instructors' names for each training module. Include learning objective and outline for each training module.
- B. Demonstration and Training Videotapes: Submit two copies within seven days of end of each training module.

1.3 QUALITY ASSURANCE

- A. Facilitator Qualifications: A firm or individual experienced in training or educating maintenance personnel in a training program similar in content and extent to that indicated for this Project, and whose work has resulted in training or education with a record of successful learning performance.
- B. Instructor Qualifications: A factory-authorized service representative, complying with requirements in Division 1 Section "Quality Requirements," experienced in operation and maintenance procedures and training.
- C. Pre-instruction Conference: Conduct conference at Project site. Review methods and procedures related to demonstration and training.
- D. Coordinate content of training modules with content of approved emergency, operation, and maintenance manuals. Do not submit instruction program until operation and maintenance data has been reviewed and approved by OWNER and CONSULTANT.

PART 2 - PRODUCTS

2.1 INSTRUCTION PROGRAM

- A. Program Structure: Develop an instruction program that includes individual training modules for each system and equipment not part of a system, as required by individual Specification Sections, and as follows:
1. Projectors
 2. Audio Visual System interface
- B. Training Modules: Develop a learning objective and teaching outline for each module. Include a description of specific skills and knowledge that participant is expected to master. For each module, include instruction for the following:
1. Basis of System Design, Operational Requirements, and Criteria: Include system and equipment descriptions, operating standards, regulatory requirements, equipment function, operating characteristics, limiting conditions, and performance curves.
 2. Documentation: Review emergency, operations, and maintenance manuals; Project Record Documents; identification systems; warranties and bonds; and maintenance service agreements.
 3. Emergencies: Include instructions on stopping; shutdown instructions; operating instructions for conditions outside normal operating limits; instructions on meaning of warnings, trouble indications, and error messages; and required sequences for electric or electronic systems.
 4. Operations: Include startup, break-in, control, and safety procedures; stopping and normal shutdown instructions; routine, normal, seasonal, and weekend operating instructions; operating procedures for emergencies and equipment failure; and required sequences for electric or electronic systems.
 5. Adjustments: Include alignments and checking, noise, vibration, economy, and efficiency adjustments.
 6. Troubleshooting: Include diagnostic instructions and test and inspection procedures.
 7. Maintenance: Include inspection procedures, types of cleaning agents, methods of cleaning, procedures for preventive and routine maintenance, and instruction on use of special tools.
 8. Repairs: Include diagnosis, repair, and disassembly instructions; instructions for identifying parts; and review of spare parts needed for operation and maintenance.

PART 3 - EXECUTION

3.1 INSTRUCTION

- A. Facilitator: Engage a qualified facilitator to prepare instruction program and training modules, to coordinate instructors, and to coordinate between CONTRACTOR and OWNER for number of participants, instruction times, and location.

- B. Prior to training, provide a training schedule and agenda for approval within 5 days of training.
- C. Engage qualified instructors to instruct OWNER's personnel to adjust, operate, and maintain systems, subsystems, and equipment not part of a system.
- D. Scheduling: Provide instruction at mutually agreed on times. For equipment that requires seasonal operation, provide similar instruction at start of each season.
 - 1. Schedule training with OWNER with at least 20 days' advance notice.
- E. Evaluation: At conclusion of each training module, assess and document each participant's mastery of module by use of an oral performance-based test.

3.2 DEMONSTRATION AND TRAINING VIDEOTAPES

- A. General: Engage a qualified commercial photographer to record demonstration and training videotapes. Record each training module separately. Include classroom instructions and demonstrations, board diagrams, and other visual aids, but not student practice.
 - 1. At beginning of each training module, record each chart containing learning objective and lesson outline.
- B. Videotape Format: Provide high-quality DVD.

END OF SECTION 01820

SECTION 06412 - PLASTIC-LAMINATE-FACED ARCHITECTURAL CABINETS

PART 1 - GENERAL

1.1 SUMMARY

A. Section Includes:

1. Plastic-laminate-faced architectural cabinets (projector housing).
2. Wood nailers, furring, blocking, shims, and hanging strips for installing plastic-laminate- faced architectural cabinets unless concealed within other construction before cabinet installation.

1.2 SUBMITTALS

A. Product Data: For products indicated, including high-pressure decorative laminate and cabinet hardware and accessories.

B. Shop Drawings: Show location of each item, dimensioned plans and elevations, large- scale details, attachment devices, and other components.

1. Show locations and sizes of furring, blocking, and hanging strips, including concealed blocking and reinforcement specified in other Sections.
2. Show locations and sizes of cutouts and holes for electrical switches and outlets and other items installed in architectural plastic-laminate cabinets.
3. Apply AWI Quality Certification Program label to Shop Drawings.

C. Samples for Verification:

1. Plastic laminates, 8 by 10 inches, for each color, pattern, and surface finish, with one sample applied to core material.

1.3 QUALITY ASSURANCE

A. Fabricator Qualifications: Shop that employs skilled workers who custom fabricate products similar to those required for this Project and whose products have a record of successful in-service performance. Shop is a certified participant in AWI's Quality Certification Program.

B. Pre-installation Conference: Conduct conference at Project site.

1.4 DELIVERY, STORAGE, AND HANDLING

- A. Do not deliver cabinets until painting and similar operations that could damage woodwork have been completed in installation areas. If cabinets must be stored in other than installation areas, store only in areas where environmental conditions comply with requirements specified in Field Conditions Article.

1.5 FIELD CONDITIONS

- A. Environmental Limitations: Do not deliver or install cabinets until building is enclosed, wet work is complete, and HVAC system is operating and maintaining temperature and relative humidity at occupancy levels during the remainder of the construction period.
- B. Field Measurements: Where cabinets are indicated to fit to other construction, verify dimensions of other construction by field measurements before fabrication, and indicate measurements on Shop Drawings. Coordinate fabrication schedule with construction progress to avoid delaying the Work.
 - 1. Locate concealed framing, blocking, and reinforcements that support cabinets by field measurements before being enclosed, and indicate measurements on Shop Drawings.
- C. Established Dimensions: Where cabinets are indicated to fit to other construction, establish dimensions for areas where cabinets are to fit. Provide allowance for trimming at site, and coordinate construction to ensure that actual dimensions correspond to established dimensions.

1.6 COORDINATION

- A. Coordinate sizes and locations of framing, blocking, furring, reinforcements, structural steel, and other related units of Work specified in other Sections to ensure that cabinets can be supported and installed as indicated.

PART 2 - PRODUCTS

2.1 PLASTIC-LAMINATE-FACED ARCHITECTURAL CABINETS

- A. Quality Standard: Unless otherwise indicated, comply with the "Architectural Woodwork Standards" for grades of plastic-laminate-faced architectural cabinets indicated for construction, finishes, installation, and other requirements.

1. Provide labels and certificates from AWI certification program indicating that woodwork complies with requirements of grades specified.

B. Acceptable Manufacturers:

1. Formica Laminate, Solid Colors Series
2. Wilsonart Laminate, Compact Laminate Series (Solid Colors)
3. Nevamar, Decorative Surfaces Series (Solid Colors)

2.2 PLASTIC-LAMINATE-FACED ARCHITECTURAL

CABINETS

A. Grade: Custom.

B. Type of Construction: As indicated.

C. Cabinet, Door Interface Style: As indicated.

D. High-Pressure Decorative Laminate: NEMA LD 3, grades as indicated or if not indicated, as required by woodwork quality standard.

1. Products and Manufacturers: Refer to Arch Drawings.

E. Laminate Cladding for Exposed Surfaces:

1. Horizontal Surfaces: Grade HGS.
2. Vertical Surfaces: Grade VGS.
3. Edges: Grade HGS.

F. Materials for Semi-exposed Surfaces:

1. Surfaces Other Than Exterior Panels: High-pressure decorative laminate, NEMA LD 3, Grade CLS.
 - a. For semi-exposed backs of panels with exposed plastic-laminate surfaces, provide surface of high-pressure decorative laminate, NEMA LD 3, Grade CLS.

G. Colors, Patterns, and Finishes: Provide materials and products that result in colors and textures of exposed laminate surfaces complying with the following requirements:

1. Refer to the Arch Drawings.
2. Final Color Selection by Architect from Manufacturer's full range of

laminate color selection.

2.3 WOOD MATERIALS

- A. Wood Products: Provide materials that comply with requirements of referenced quality standard for each type of woodwork and quality grade specified unless otherwise indicated.
- B. Product Data: For each type of process and factory-fabricated product. Indicate component materials and dimensions and include construction and application details.
 - 1. Include data for fire-retardant treatment from chemical treatment manufacturer and certification by treating plant that treated materials comply with requirements.
Include physical properties of treated materials, both before and after exposure to elevated temperatures when tested according to ASTM D 5516 and ASTM D 5664.
- C. Research/Evaluation Reports: For the following, showing compliance with building code in effect for Project:
 - 1. Preservative-treated wood.
 - 2. Fire-retardant-treated wood.

2.4 QUALITY ASSURANCE

- A. Source Limitations for Fire-Retardant-Treated Wood: Obtain each type of fire-retardant-treated wood product through one source from a single producer.

2.5 DELIVERY, STORAGE, AND HANDLING

- A. Keep materials under cover and dry. Protect from weather and contact with damp or wet surfaces. Stack lumber, plywood, and other panels. Provide for air circulation within and around stacks and under temporary coverings.
- D. Plywood: APA Grade A-C; HPVA HP-1, made with adhesive containing no urea formaldehyde.

1. Thickness: 3/4-inch unless otherwise indicated.

2.6 FIRE-RETARDANT-TREATED MATERIALS

- A. General: Where fire-retardant-treated materials are indicated, provide materials that comply with performance requirements in AWWPA C20 (lumber). Identify fire-retardant-treated wood with appropriate classification marking of UL, U.S. Testing, Timber Products Inspection, or another testing and inspecting agency acceptable to authorities having jurisdiction.
 1. Use treatment for which chemical manufacturer publishes physical properties of treated wood after exposure to elevated temperatures, when tested by a qualified independent testing agency according to ASTM D 5664, for lumber.
 2. Use treatment that does not promote corrosion of metal fasteners.
 3. Use Interior Type A unless otherwise indicated.
- B. Identify fire-retardant-treated wood with appropriate classification marking of testing and inspecting agency acceptable to authorities having jurisdiction.
- C. Application: Treat items indicated on Drawings, and the following:
 1. Concealed blocking.

2.7 CABINET HARDWARE AND ACCESSORIES

- A. General: Provide cabinet hardware and accessory materials associated with architectural cabinets.
- B. Hinges: Concealed, overlay, self-closing, all metal, 165-degree opening, independent screw action. Hinge plate shall be T-type, fully adjustable. Provide number of hinges per door as recommended by the manufacturer based on door dimensions.
 1. Products and Manufacturer: Subject to compliance with requirements, available products and manufacturers that may be incorporated into the Work include, but are not limited to, the following:
 - a. Blum, Inc.
 - b. Grass America, Inc.
 - c. Hafele America Co.

2.8 MISCELLANEOUS MATERIALS

- A. Furring, Blocking, Shims, and Hanging Strips: Softwood or hardwood lumber, kiln dried to less than 15 percent moisture content.
- B. Anchors: Select material, type, size, and finish required for each substrate for secure anchorage. Provide metal expansion sleeves or expansion bolts for post-installed anchors. Use nonferrous-metal or hot-dip galvanized anchors and inserts at inside face of exterior walls and at floors.
- C. Adhesives: Do not use adhesives that contain urea formaldehyde.
- D. Sliding Rack System:
 - 1. Basis of Design: Accuride Full Extension Extra Heavy Duty Slides and Associated Hardware, Model # 9301 Bottom Mounted, Item # 422.10.990 or Approved Equal
 - 2. Requirements (Basis of Design):
 - Minimum load rating: 150lbs
 - Material: Stainless Steel
 - Length: As per projector cage / projector manufacturer requirements
 - 3. Follow manufacturer's installation requirements
- E. Perforated Metal Panel:
 - 1. Basis of Design: McNichols, Round Hole Perforated or Approved Equal
 - 2. Requirements (Basis of Design):
 - Hole Diameter: 1/4" Round
 - Centers: 3/8" Stg
 - Gauge: 18
 - Material: Stainless Steel 304
 - % O/A: 40%

2.9 FABRICATION

- A. General: Fabricate cabinets (projector housing) to dimensions, profiles, and details indicated.
 - 1. Complete fabrication, including assembly and hardware application, to maximum extent possible before shipment to Project site. Disassemble components only as necessary for shipment and installation. Where necessary for fitting at site, provide ample allowance for scribing, trimming, and fitting.

2. Shop-cut openings to maximum extent possible to receive hardware, appliances, electrical work, and similar items. Locate openings accurately and use templates or roughing-in diagrams to produce accurately sized and shaped openings. Sand edges of cutouts to remove splinters and burrs.
- B. Veneer Core Substrate: Plywood, unless otherwise indicated.

PART 3 - EXECUTION

3.1 PREPARATION

- A. Before installation, condition cabinets to average prevailing humidity conditions in installation areas.
- B. Before installing cabinets, examine shop-fabricated work for completion and complete work as required.

3.2 INSTALLATION

- A. Grade: Install cabinets to comply with same grade as item to be installed.
- B. Assemble cabinets and complete fabrication at Project site to the extent that it was not completed in the shop.
- C. Install cabinets level, plumb, true, and straight. Shim as required with concealed shims. Install level and plumb to a tolerance of 1/8 inch in 96 inches.
- D. Scribe and cut cabinets to fit adjoining work, refinish cut surfaces, and repair damaged finish at cuts.
- E. Anchor cabinets to anchors or blocking built in or directly attached to substrates.
Secure with countersunk, concealed fasteners and blind nailing. Use fine finishing nails or finishing screws for exposed fastening, countersunk and filled flush with
woodwork.
 1. Use filler matching finish of items being installed.
- F. Cabinets: Install without distortion so doors and drawers fit openings properly and are accurately aligned. Adjust hardware to center doors and drawers in openings and to provide unencumbered operation. Complete installation of hardware and accessory items as indicated.
 1. Install cabinets with no more than 1/8 inch in 96-inch sag, bow, or other

variation from a straight line.

3.3 ADJUSTING AND CLEANING

- A. Repair damaged and defective cabinets, where possible, to eliminate functional and visual defects; where not possible to repair, replace woodwork. Adjust joinery for uniform appearance.
- B. Clean, lubricate, and adjust hardware.
- C. Clean cabinets on exposed and semi-exposed surfaces.

END OF SECTION 06412

SECTION 16050 - BASIC ELECTRICAL MATERIALS & METHODS

PART 1 - GENERAL

1.1 SUMMARY

- A. This Section includes the following:
1. Electrical equipment coordination and installation.
 2. Sleeves for raceways and cables.
 3. Sleeve seals.
 4. Common electrical installation requirements.

1.2 SUBMITTALS

- A. Product Data: For each type of product indicated.

1.3 QUALITY ASSURANCE

- A. Test Equipment Suitability and Calibration: Comply with NETA ATS, "Suitability of Test Equipment" and "Test Instrument Calibration."

1.4 COORDINATION

- A. Coordinate arrangement, mounting, and support of electrical equipment:
1. To allow maximum possible headroom unless specific mounting heights that reduce headroom are indicated.
 2. To provide for ease of disconnecting the equipment with minimum interference to other installations.
 3. To allow right of way for piping and conduit installed at required slope.
 4. So connecting raceways, cables, wireways, cable trays, and busways will be clear of obstructions and of the working and access space of other equipment.
 5. So that underground raceways that extend under the building grade slab are routed clear of footings, grade beams and similar including drainage provisions and the work of other trades. Where the number of sweeps or bends exceeds practical limits, furnish and install hand holes, manholes and similar appurtenances to facilitate the pulling in of cables.
 6. So that raceways run "overhead" are located at elevations and in such a manner that does not interfere with the work of other trades or restrict proper use and access of the area or space in which the raceway is located. In particular locate circuitry to Connector Strips at a suitable elevation above the catwalks.

- B. Coordinate installation of required supporting devices and set sleeves in cast-in-place concrete, masonry walls, and other structural components as they are constructed.
- C. Coordinate location of access panels and doors for electrical items that are behind finished surfaces or otherwise concealed. Access doors and panels are specified in Division 8 Section "Access Doors and Frames."
- D. Coordinate electrical testing of electrical, mechanical, and architectural items, so equipment and systems that are functionally interdependent are tested to demonstrate successful interoperability.

PART 2 - PRODUCTS

2.1 SLEEVES FOR RACEWAYS AND CABLES

- A. Steel Pipe Sleeves: ASTM A 53/A 53M, Type E, Grade B, Schedule 40, galvanized steel, plain ends.
- B. Cast-Iron Pipe Sleeves: Cast or fabricated "wall pipe," equivalent to ductile-iron pressure pipe, with plain ends and integral waterstop, unless otherwise indicated.
- C. Coordinate sleeve selection and application with selection and application of firestopping specified in Division 7 Section "Through-Penetration Firestop Systems."

2.2 SLEEVE SEALS

- A. Description: Modular sealing device, designed for field assembly, to fill annular space between sleeve and raceway or cable.
 - 1. Sealing Elements: EPDM interlocking links shaped to fit surface of cable or conduit. Include type and number required for material and size of raceway or cable.
 - 2. Pressure Plates: Plastic. Include two for each sealing element.
 - 3. Connecting Bolts and Nuts: Carbon steel with corrosion-resistant coating of length required to secure pressure plates to sealing elements. Include one for each sealing element.

PART 3 - EXECUTION

3.1 COMMON REQUIREMENTS FOR ELECTRICAL INSTALLATION

- A. Comply with NECA 1.

- B. Measure indicated mounting heights to bottom of unit for suspended items and to center of unit for wall-mounting items.
- C. Headroom Maintenance: If mounting heights or other location criteria are not indicated, arrange and install components and equipment to provide maximum possible headroom consistent with these requirements.
- D. Equipment: Install to facilitate service, maintenance, and repair or replacement of components of both electrical equipment and other nearby installations. Connect in such a way as to facilitate future disconnecting with minimum interference with other items in the vicinity.
- E. Right of Way: Give to raceways and piping systems installed at a required slope.

3.2 SLEEVE INSTALLATION FOR ELECTRICAL PENETRATIONS

- A. Electrical penetrations occur when raceways, cables, wireways, cable trays, or busways penetrate concrete slabs, concrete or masonry walls, or fire-rated floor and wall assemblies.
- B. Coordinate sleeve selection and application with selection and application of firestopping specified in Division 7 Section "Through-Penetration Firestop Systems."
- C. Concrete Slabs and Walls: Install sleeves for penetrations unless core-drilled holes or formed openings are used. Install sleeves during erection of slabs and walls.
- D. Fire-Rated Assemblies: Install sleeves for penetrations of fire-rated floor and wall assemblies unless openings compatible with firestop system used are fabricated during construction of floor or wall.
- E. Cut sleeves to length for mounting flush with both surfaces of walls.
- F. Extend sleeves installed in floors 2 inches (50 mm) above finished floor level.
- G. Size pipe sleeves to provide 1/4-inch (6.4-mm) annular clear space between sleeve and raceway or cable unless sleeve seal is to be installed.
- H. Seal space outside of sleeves with grout for penetrations of concrete and masonry and with approved joint compound for gypsum board assemblies.
- I. Interior Penetrations of Non-Fire-Rated Walls and Floors: Seal annular space between sleeve and raceway or cable, using joint sealant appropriate for size, depth, and location of joint. Refer to Division 7 Section "Joint Sealants" for materials and installation.
- J. Fire-Rated-Assembly Penetrations: Maintain indicated fire rating of walls, partitions, ceilings, and floors at raceway and cable penetrations. Install sleeves and seal

raceway and cable penetration sleeves with firestop materials. Comply with Division 7 Section "Through-Penetration Firestop Systems."

- K. Roof-Penetration Sleeves: Seal penetration of individual raceways and cables with flexible boot-type flashing units applied in coordination with roofing work.
- L. Aboveground, Exterior-Wall Penetrations: Seal penetrations using sleeves and mechanical sleeve seals. Select sleeve size to allow for 1-inch (25-mm) annular clear space between pipe and sleeve for installing mechanical sleeve seals.
- M. Underground, Exterior-Wall Penetrations: Install cast-iron "wall pipes" for sleeves. Size sleeves to allow for 1-inch (25-mm) annular clear space between raceway or cable and sleeve for installing mechanical sleeve seals.

3.3 FIRESTOPPING

- A. Apply firestopping to electrical penetrations of fire-rated floor and wall assemblies to restore original fire-resistance rating of assembly. Firestopping materials and installation requirements are specified in Division 7 Section "Through-Penetration Firestop Systems."

END OF SECTION 16050

SECTION 16060 - GROUNDING AND BONDING

PART 1 - GENERAL

1.1 SUMMARY

- A. This Section includes methods and materials for grounding systems and equipment.

1.2 SUBMITTALS

- A. Product Data: For each type of product indicated.
- B. Field quality-control test reports.

1.3 QUALITY ASSURANCE

- A. Electrical Components, Devices, and Accessories: Listed and labeled as defined in NFPA 70, Article 100, by a testing agency acceptable to authorities having jurisdiction, and marked for intended use.
- B. Comply with UL 467 for grounding and bonding materials and equipment.

PART 2 - PRODUCTS

2.1 CONDUCTORS

- A. Insulated Conductors: Copper wire or cable insulated for 600 V unless otherwise required by applicable Code or authorities having jurisdiction.
- B. Bare Copper Conductors:
 - 1. Solid Conductors: ASTM B 3.
 - 2. Stranded Conductors: ASTM B 8.
 - 3. Tinned Conductors: ASTM B 33.
 - 4. Bonding Cable: 3/0 stranded.
 - 5. Bonding Conductor: No. 4, stranded conductor.
 - 6. Bonding Jumper: Copper tape, braided conductors, terminated with copper ferrules; 1-5/8 inches (41 mm) wide and 1/16 inch (1.6 mm) thick.

2.2 CONNECTORS

- A. Listed and labeled by a nationally recognized testing laboratory acceptable to authorities having jurisdiction for applications in which used, and for specific types, sizes, and combinations of conductors and other items connected.
- B. Bolted Connectors for Conductors and Pipes: Copper or copper alloy, bolted pressure-type, with at least two bolts.
 - 1. Pipe Connectors: Clamp type, sized for pipe.
- C. Welded Connectors: Exothermic-welding kits of types recommended by kit manufacturer for materials being joined and installation conditions.

2.3 GROUNDING ELECTRODES

- A. Ground Rods: copper-clad steel $\frac{3}{4}$ " x 20'.

PART 3 - EXECUTION

3.1 APPLICATIONS

- A. Conductors: Install solid conductor for #10 AWG and smaller, and stranded conductors for #8 AWG and larger, unless otherwise indicated.
- B. Underground Grounding Conductors: Install bare copper conductor, No. 3/0 AWG minimum. Bury at least 24 inches (600 mm) below grade.
- C. Isolated Grounding Conductors: Green-colored insulation with continuous yellow stripe. On feeders with isolated ground, identify grounding conductor where visible to normal inspection, with alternating bands of green and yellow tape, with at least three bands of green and two bands of yellow.
- D. Conductor Terminations and Connections:
 - 1. Pipe and Equipment Grounding Conductor Terminations: Bolted connectors.
 - 2. Underground Connections: Welded connectors, except at test wells and as otherwise indicated.
 - 3. Connections to Ground Rods at Test Wells: Bolted connectors.
 - 4. Connections to Structural Steel: Welded connectors.

3.2 EQUIPMENT GROUNDING

- A. Install insulated equipment grounding conductors with the following items, in addition to those required by NFPA 70:
1. Feeders and branch circuits.
 2. Lighting circuits.
 3. Receptacle circuits.
 4. Single-phase motor and appliance branch circuits.
 5. Three-phase motor and appliance branch circuits.
 6. Flexible raceway runs.
 7. Armored and metal-clad cable runs.
 8. Busway Supply Circuits: Install insulated equipment grounding conductor from grounding bus in the switchgear, switchboard, or distribution panel to equipment grounding bar terminal on busway.
 9. Computer and Rack-Mounted Electronic Equipment Circuits: Install insulated equipment grounding conductor in branch-circuit runs from equipment-area power panels and power-distribution units.
- B. Air-Duct Equipment Circuits: Install insulated equipment grounding conductor to duct-mounted electrical devices operating at 120 V and more, including air cleaners, heaters, dampers, humidifiers, and other duct electrical equipment. Bond conductor to each unit and to air duct and connected metallic piping.
- C. Water Heater: Install a separate insulated equipment grounding conductor to each electric water heater. Bond conductor to heater units, piping, connected equipment, and components.
- D. Isolated Grounding Receptacle Circuits: Install an insulated equipment grounding conductor connected to the receptacle grounding terminal. Isolate conductor from raceway and from panelboard grounding terminals. Terminate at equipment grounding conductor terminal of the applicable derived system or service, unless otherwise indicated.
- E. Isolated Equipment Enclosure Circuits: For designated equipment supplied by a branch circuit or feeder, isolate equipment enclosure from supply circuit raceway with a nonmetallic raceway fitting listed for the purpose. Install fitting where raceway enters enclosure, and install a separate insulated equipment grounding conductor. Isolate conductor from raceway and from panelboard grounding terminals. Terminate at equipment grounding conductor terminal of the applicable derived system or service, unless otherwise indicated.
- F. Signal and Communication Equipment: For telephone, alarm, voice and data, and other communication equipment, provide No. 4 AWG minimum insulated grounding

conductor in raceway from grounding electrode system to each service location, terminal cabinet, wiring closet, and central equipment location.

1. Service and Central Equipment Locations and Wiring Closets: Terminate grounding conductor on a 1/4-by-2-by-12-inch (6-by-50-by-300-mm) grounding bus.
 2. Terminal Cabinets: Terminate grounding conductor on cabinet grounding terminal.
- G. Metal or Wood Poles Supporting Outdoor Lighting Fixtures: Install grounding electrode and a separate insulated equipment grounding conductor in addition to grounding conductor installed with branch-circuit conductors.

3.3 INSTALLATION

- A. Grounding Conductors: Route along shortest and straightest paths possible, unless otherwise indicated or required by Code. Avoid obstructing access or placing conductors where they may be subjected to strain, impact, or damage.
- B. Ground Rods: Drive rods until tops are 2 inches (50 mm) below finished floor or final grade, unless otherwise indicated.
1. Interconnect ground rods with grounding electrode conductor below grade and as otherwise indicated. Make connections without exposing steel or damaging coating, if any.
 2. For grounding electrode system, install at least three rods spaced at least one-rod length from each other and located at least the same distance from other grounding electrodes, and connect to the service grounding electrode conductor.
- C. Test Wells: Ground rod driven through drilled hole in bottom of handhole. Handholes are specified in Division 2 Section "Underground Ducts and Utility Structures," and shall be at least 12 inches (300 mm) deep, with cover.
1. Test Wells: Install at least one test well for each service, unless otherwise indicated. Install at the ground rod electrically closest to service entrance. Set top of test well flush with finished grade or floor.
- D. Bonding Straps and Jumpers: Install in locations accessible for inspection and maintenance, except where routed through short lengths of conduit.
1. Bonding to Structure: Bond straps directly to basic structure, taking care not to penetrate any adjacent parts.
 2. Bonding to Equipment Mounted on Vibration Isolation Hangers and Supports: Install so vibration is not transmitted to rigidly mounted equipment.

3. Use exothermic-welded connectors for outdoor locations, but if a disconnect-type connection is required, use a bolted clamp.

E. Grounding and Bonding for Piping:

1. Metal Water Service Pipe: Install insulated copper grounding conductors, in conduit, from building's main service equipment, or grounding bus, to main metal water service entrances to building. Connect grounding conductors to main metal water service pipes, using a bolted clamp connector or by bolting a lug-type connector to a pipe flange, using one of the lug bolts of the flange. Where a dielectric main water fitting is installed, connect grounding conductor on street side of fitting. Bond metal grounding conductor conduit or sleeve to conductor at each end.
2. Water Meter Piping: Use braided-type bonding jumpers to electrically bypass water meters. Connect to pipe with a bolted connector.
3. Bond each aboveground portion of gas piping system downstream from equipment shutoff valve.

- F. Bonding Interior Metal Ducts: Bond metal air ducts to equipment grounding conductors of associated fans, blowers, electric heaters, and air cleaners. Install tinned bonding jumper to bond across flexible duct connections to achieve continuity.

3.4 FIELD QUALITY CONTROL

A. Perform the following tests and inspections and prepare test reports:

1. After installing grounding system but before permanent electrical circuits have been energized, test for compliance with requirements.
2. Test completed grounding system at each location where a maximum ground-resistance level is specified, at service disconnect enclosure grounding terminal, and at ground test wells.
 - a. Measure ground resistance not less than two full days after last trace of precipitation and without soil being moistened by any means other than natural drainage or seepage and without chemical treatment or other artificial means of reducing natural ground resistance.
 - b. Perform tests by fall-of-potential method according to IEEE 81.

B. Report measured ground resistances that exceed the following values:

1. Power and Lighting Equipment or System with Capacity 500 kVA and Less: 10 ohms.
2. Power and Lighting Equipment or System with Capacity 500 to 1000 kVA: 5 ohms.

3. Power and Lighting Equipment or System with Capacity More Than 1000 kVA: 3 ohms.
 4. Power Distribution Units or Panelboards Serving Electronic Equipment: 1 ohm(s).
- C. Excessive Ground Resistance: If resistance to ground exceeds specified values, notify engineer promptly and include recommendations to reduce ground resistance.

END OF SECTION 16060

SECTION 16072 - ELECTRICAL SUPPORTS

PART 1 - GENERAL

1.1 SUMMARY

- A. This Section includes the following:
 - 1. Hangers and supports for electrical equipment and systems.
 - 2. Construction requirements for concrete bases.

1.2 SUBMITTALS

- A. Product Data: Illustrate and indicate style, material, strength, fastening provision, and finish for each type and size of component used.

1.3 QUALITY ASSURANCE

- A. Welding: Qualify procedures and personnel according to AWS D1.1/D1.1M, "Structural Welding Code - Steel."

PART 2 - PRODUCTS

2.1 MANUFACTURERS

- A. In other Part 2 articles where titles below introduce lists, the following requirements apply to product selection:
 - 1. Available Manufacturers: Subject to compliance with requirements, manufacturers offering products that may be incorporated into the Work include, but are not limited to, manufacturers specified.
 - 2. Manufacturers: Subject to compliance with requirements, provide products by one of the manufacturers specified.

2.2 SUPPORT, ANCHORAGE, AND ATTACHMENT COMPONENTS

- A. Rated Strength: Adequate in tension, shear, and pullout force to resist maximum loads calculated or imposed under this Project, with a minimum structural safety factor of 5 times the applied force.

- B. Steel Slotted Support Systems: Comply with MFMA-3, factory-fabricated components for field assembly, and provide finish suitable for the environment in which installed.
1. Manufacturers:
 - a. Cooper B-Line; a division of Cooper Industries.
 - b. ERICO International Corporation.
 - c. Allied Support Systems; Power-Strut Unit.
 - d. GS Metals Corp.
 - e. Michigan Hanger Co., Inc.; O-Strut Div.
 - f. National Pipe Hanger Corp.
 - g. Thomas & Betts Corporation.
 - h. Unistrut; Tyco International, Ltd.
 - i. Wesanco, Inc.
 2. Channel Dimensions: Selected for structural loading
- C. Raceway and Cable Supports: As described in NECA 1.
- D. Conduit and Cable Support Devices: Steel hangers, clamps, and associated fittings, designed for types and sizes of raceway or cable to be supported.
- E. Support for Conductors in Vertical Conduit: Factory-fabricated assembly consisting of threaded body and insulating wedging plug or plugs for non-armored electrical conductors or cables in riser conduits. Plugs shall have number, size, and shape of conductor gripping pieces as required to suit individual conductors or cables supported. Body shall be malleable iron.
- F. Structural Steel for Fabricated Supports and Restraints: ASTM A 36/A 36M, steel plates, shapes, and bars; black and galvanized.
- G. Mounting, Anchoring, and Attachment Components: Items for fastening electrical items or their supports to building surfaces include the following:
1. Mechanical-Expansion Anchors: Insert-wedge-type, zinc-coated steel, for use in hardened portland cement concrete with tension, shear, and pullout capacities appropriate for supported loads and building materials in which used.
 - a. Manufacturers:
 - 1) Cooper B-Line; a division of Cooper Industries.
 - 2) Empire Tool and Manufacturing Co., Inc.
 - 3) Hilti, Inc.
 - 4) ITW Construction Products.
 - 5) MKT Fastening, LLC.
 - 6) Powers Fasteners.

2. Concrete Inserts: Steel or malleable-iron slotted-support-system units similar to MSS Type 18; complying with MFMA-3 or MSS SP-58.
3. Clamps for Attachment to Steel Structural Elements: MSS SP-58, type suitable for attached structural element.
4. Through Bolts: Structural type, hex head, high strength. Comply with ASTM A 325.
5. Toggle Bolts: All-steel springhead type.
6. Hanger Rods: Threaded steel.

2.3 FABRICATED METAL EQUIPMENT SUPPORT ASSEMBLIES

- A. Description: Welded or bolted, structural-steel shapes, shop or field fabricated to fit dimensions of supported equipment.
- B. Materials: Comply with requirements in Division 5 Section "Metal Fabrications" for steel shapes and plates.

PART 3 - EXECUTION

3.1 APPLICATION

- A. Comply with NECA 1 for application of hangers and supports for electrical equipment and systems, unless requirements in this Section or applicable Code are stricter.

3.2 SUPPORT INSTALLATION

- A. Comply with NECA 1 for installation requirements, except as specified in this Article.
- B. Raceway Support Methods: In addition to methods described in NECA 1, EMT may be supported by openings through structure members, as permitted in NFPA 70.
- C. Strength of Support Assemblies: Where not indicated, select sizes of components so strength will be adequate to carry present and future static loads within specified loading limits. Minimum static design load used for strength determination shall be weight of supported components plus 200 lb (90 kg).
- D. Mounting and Anchorage of Surface-Mounted Equipment and Components: Anchor and fasten electrical items and their supports to building structural elements by the following methods, unless otherwise indicated by Code:
 1. To Wood: Fasten with lag screws or through bolts.
 2. To New Concrete: Bolt to concrete inserts.

3. To Masonry: Approved toggle-type bolts on hollow masonry units and expansion anchor fasteners on solid masonry units.
 4. To Existing Concrete: Expansion anchor fasteners.
 5. To Steel: [Welded threaded studs complying with AWS D1.1/D1.1M, with lock washers and nuts] [Beam clamps (MSS Type 19, 21, 23, 25, or 27) complying with MSS SP-69] [Spring-tension clamps].
 6. To Light Steel: Sheet metal screws.
 7. Items Mounted on Hollow Walls and Nonstructural Building Surfaces: Mount on slotted-channel racks attached to substrate.
- E. Drill holes for expansion anchors in concrete at locations and to depths that avoid reinforcing bars.

3.3 INSTALLATION OF FABRICATED METAL SUPPORTS

- A. Comply with installation requirements in Division 5 Section "Metal Fabrications" for site-fabricated metal supports.
- B. Cut, fit, and place miscellaneous metal supports accurately in location, alignment, and elevation to support and anchor electrical materials and equipment.
- C. Field Welding: Comply with AWS D1.1/D1.1M.

3.4 CONCRETE BASES

- A. Concrete Bases: Anchor equipment to concrete base according to equipment manufacturer's written instructions.
- B. Construct concrete bases of dimensions indicated but not less than 4 inches (100 mm) larger in both directions than supported unit, and so expansion anchors will be a minimum of 10 bolt diameters from edge of the base.
 1. Install dowel rods to connect concrete base to concrete floor. Unless otherwise indicated, install dowel rods on 18-inch (450-mm) centers around full perimeter of the base.
 2. Install epoxy-coated anchor bolts for supported equipment that extend through concrete base, and anchor into structural concrete floor.
 3. Place and secure anchorage devices. Use supported equipment manufacturer's setting drawings, templates, diagrams, instructions, and directions furnished with items to be embedded.
 4. Install anchor bolts to elevations required for proper attachment to supported equipment.
 5. Install anchor bolts according to anchor-bolt manufacturer's written instructions.

6. Use 3000-psi (20.7-MPa)], 28-day compressive-strength concrete. Concrete materials, reinforcement, and placement requirements are specified in Division 3 Section "Cast-in-Place Concrete (Limited Applications)."

END OF SECTION 16072

SECTION 16075 - ELECTRICAL IDENTIFICATION

PART 1 - GENERAL

1.1 SUMMARY

A. This Section includes the following:

1. Identification for conductors and communication and control cable.
2. Warning labels and signs.
3. Equipment identification labels.

1.2 SUBMITTALS

A. Product Data: For each electrical identification product indicated.

1.3 QUALITY ASSURANCE

A. Comply with ANSI A13.1.

1.4 COORDINATION

A. Coordinate identification names, abbreviations, colors, and other features with requirements in the Contract Documents, Shop Drawings, manufacturer's wiring diagrams, and the Operation and Maintenance Manual, and with those required by codes, standards, and 29 CFR 1910.145. Use consistent designations throughout Project.

PART 2 - PRODUCTS

2.1 CONDUCTOR AND COMMUNICATION- AND CONTROL-CABLE IDENTIFICATION MATERIALS

A. Marker Tape: Vinyl or vinyl -cloth, self-adhesive wraparound type, with circuit identification legend machine printed by thermal transfer or equivalent process.

2.2 WARNING LABELS AND SIGNS

A. Comply with NFPA 70, NFPA 70 E and 29 CFR 1910.145.

- B. Self-Adhesive Warning Labels: Factory printed, multicolor, pressure-sensitive adhesive labels, configured for display on front cover, door, or other access to equipment, unless otherwise indicated.
- C. Baked-Enamel Warning Signs: Preprinted aluminum signs, punched or drilled for fasteners, with colors, legend, and size required for application. 1/4-inch (6.4-mm) grommets in corners for mounting. Nominal size, 7 by 10 inches (180 by 250 mm).
- D. Metal-Backed, Butyrate Warning Signs: Weather-resistant, nonfading, preprinted, cellulose-acetate butyrate signs with 0.0396-inch (1-mm) galvanized-steel backing; and with colors, legend, and size required for application. 1/4-inch (6.4-mm) grommets in corners for mounting. Nominal size, 10 by 14 inches (250 by 360 mm).
- E. Fasteners for Signs: Self-tapping, stainless-steel screws or stainless-steel machine screws with nuts and flat and lock washers.
- F. Warning label and sign shall include, but are not limited to, the following legends:
 - 1. Multiple Power Source Warning: "DANGER - ELECTRICAL SHOCK HAZARD - EQUIPMENT HAS MULTIPLE POWER SOURCES."
 - 2. Workspace Clearance Warning: "WARNING - OSHA REGULATION - AREA IN FRONT OF ELECTRICAL EQUIPMENT MUST BE KEPT CLEAR FOR 36 INCHES (915 mm)."
 - 3. PPE Personnel protection equipment labels identifying level of hazard and the required protective items as prescribed by NEC 70 E.

2.3 EQUIPMENT IDENTIFICATION LABELS

- A. Adhesive Film Label with Clear Protective Overlay: Machine printed, in black, by thermal transfer or equivalent process. Minimum letter height shall be 3/8 inch (10 mm). Overlay shall provide a weatherproof and ultraviolet-resistant seal for label.
- B. Self-Adhesive, Engraved, Laminated Acrylic or Melamine Label: Adhesive backed, with white letters on a dark-gray background. Minimum letter height shall be 3/8 inch (10 mm).

PART 3 - EXECUTION

3.1 APPLICATION

- A. Auxiliary Electrical Systems Conductor and Cable Identification: Use marker tape to identify field-installed alarm, control, signal, sound, intercommunications, voice, and data wiring connections.

1. Identify conductors, cables, and terminals in enclosures and at junctions, terminals, and cable pull points. Identify by system and circuit designation.
 2. Use system of designations that is uniform and consistent with system used by manufacturer for factory-installed connections.
- B. Warning Labels for Indoor Cabinets, Boxes, and Enclosures for Power and Lighting: Comply with 29 CFR 1910.145 and apply [self-adhesive warning labels]. Identify system voltage with black letters on an orange background. Apply to exterior of door, cover, or other access.
1. Equipment with Multiple Power or Control Sources: Apply to door or cover of equipment including, but not limited to, the following:
 - a. Power transfer switches.
 - b. Controls with external control power connections.
 2. Equipment Requiring Workspace Clearance According to NFPA 70: Unless otherwise indicated, apply to door or cover of equipment but not on flush panelboards and similar equipment in finished spaces.
- C. Equipment Identification Labels: On each unit of equipment, install unique designation label that is consistent with wiring diagrams, schedules, and Operation and Maintenance Manual. Apply labels to disconnect switches and protection equipment, central or master units, control panels, control stations, terminal cabinets, and racks of each system. Systems include power, lighting, control, communication, signal, monitoring, and alarm systems unless equipment is provided with its own identification.
1. Labeling Instructions:
 - a. Indoor Equipment: [Self-adhesive, engraved, laminated acrylic or melamine label]. Unless otherwise indicated, provide a single line of text with 1/2-inch- (13-mm-) high letters on 1-1/2-inch- (38-mm-) high label; where 2 lines of text are required, use labels 2 inches (50 mm) high.
 - b. Outdoor Equipment: Engraved, laminated acrylic or melamine label, drilled for screw attachment.
 - c. Elevated Components: Increase sizes of labels and legend to those appropriate for viewing from the floor.
 2. Equipment to Be Labeled:
 - a. Panelboards, electrical cabinets, and enclosures.
 - b. Electrical switchgear and switchboards.
 - c. Transformers.
 - d. Motor-control centers.
 - e. Disconnect switches.
 - f. Enclosed circuit breakers.
 - g. Motor starters.

- h. Push-button stations.
- i. Power transfer equipment.
- j. Contactors.

3.2 INSTALLATION

- A. Verify identity of each item before installing identification products.
- B. Location: Install identification materials and devices at locations for most convenient viewing without interference with operation and maintenance of equipment.
- C. Apply identification devices to surfaces that require finish after completing finish work.
- D. Self-Adhesive Identification Products: Clean surfaces before application, using materials and methods recommended by manufacturer of identification device.
- E. Attach nonadhesive signs and plastic labels with screws and auxiliary hardware appropriate to the location and substrate.
- F. Color-Coding for Phase and Voltage Level Identification, 600 V and Less: Use the colors listed below for ungrounded service, feeder, and branch-circuit conductors.
 - 1. Color shall be factory applied.
 - 2. Colors for 208/120-V Circuits:
 - a. Phase A: Black.
 - b. Phase B: Red.
 - c. Phase C: Blue.
 - 3. Colors for 480/277-V Circuits:
 - a. Phase A: Brown.
 - b. Phase B: Orange.
 - c. Phase C: Yellow.

END OF SECTION 16075

SECTION 16120 - CONDUCTORS & CABLES

PART 1 - GENERAL

1.1 SUMMARY

- A. This Section includes the following:
 - 1. Building wires and cables rated 600 V and less.
 - 2. Connectors, splices, and terminations rated 600 V and less.
 - 3. Sleeves and sleeve seals for cables.

1.2 SUBMITTALS

- A. Product Data: For each type of product indicated.
- B. Field quality-control test reports.

1.3 QUALITY ASSURANCE

- A. Electrical Components, Devices, and Accessories: Listed and labeled as defined in NFPA 70, Article 100, by a testing agency acceptable to authorities having jurisdiction, and marked for intended use.
- B. Comply with NFPA 70.

PART 2 - PRODUCTS

2.1 CONDUCTORS AND CABLES

- A. Aluminum and Copper Conductors: Comply with NEMA WC 70.
- B. Conductor Insulation: Comply with NEMA WC 70 for Types THHN-THWN, THHW and other insulation types as required based on the environment to which the conductor will be subjected.

2.2 CONNECTORS AND SPLICES

- A. Available Manufacturers: Subject to compliance with requirements, manufacturers offering products that may be incorporated into the Work include, but are not limited to, the following:

- B. Manufacturers: Subject to compliance with requirements, provide products by one of the following:
 - 1. AFC Cable Systems, Inc.
 - 2. Hubbell Power Systems, Inc.
 - 3. O-Z/Gedney; EGS Electrical Group LLC.
 - 4. 3M; Electrical Products Division.
 - 5. Tyco Electronics Corp.
 - 6. IIsco
 - 7. NSI Industries – “Polaris Taps”
- C. Description: Factory-fabricated connectors and splices of size, ampacity rating, material, type, and class for application and service indicated.
- D. Where required due to limitations on the “approved termination devices” provided with equipment (approved for use by the AHJ, the contractor shall provide “transition boxes” and connectors to allow for the reduction of conductor size (oversized to account for voltage drop) to occur without voiding warranties or violating code limitations on wire bending space, clearance or cross sectional area limits.

2.3 SLEEVES FOR CABLES

- A. Steel Pipe Sleeves: ASTM A 53/A 53M, Type E, Grade B, Schedule 40, galvanized steel, plain ends.
- B. Cast-Iron Pipe Sleeves: Cast or fabricated "wall pipe," equivalent to ductile-iron pressure pipe, with plain ends and integral waterstop, unless otherwise indicated.
- C. Coordinate sleeve selection and application with selection and application of firestopping specified in Division 7 Section "Through-Penetration Firestop Systems."

2.4 SLEEVE SEALS

- A. Available Manufacturers: Subject to compliance with requirements, manufacturers offering products that may be incorporated into the Work include, but are not limited to, the following:
- B. Manufacturers: Subject to compliance with requirements, provide products by one of the following:
- C. Basis-of-Design Product: Subject to compliance with requirements, provide the product indicated on Drawings or a comparable product by one of the following:
 - 1. Advance Products & Systems, Inc.
 - 2. Calpico, Inc.

3. Metraflex Co.
 4. Pipeline Seal and Insulator, Inc.
- D. Description: Modular sealing device, designed for field assembly, to fill annular space between sleeve and cable.
1. Sealing Elements: EPDM or NBR interlocking links shaped to fit surface of cable or conduit. Include type and number required for material and size of raceway or cable.
 2. Pressure Plates: Plastic, include two for each sealing element.
 3. Connecting Bolts and Nuts: Carbon steel with corrosion-resistant coating of length required to secure pressure plates to sealing elements. Include one for each sealing element.

PART 3 - EXECUTION

3.1 CONDUCTOR MATERIAL APPLICATIONS

- A. Feeders: Copper for feeders smaller than No. 4 AWG; copper or aluminum for feeders No. 4 AWG and larger. Solid for No. 10 AWG and smaller; stranded for No. 8 AWG and larger.
- B. Branch Circuits: Copper. Solid for No. 10 AWG and smaller; stranded for No. 8 AWG and larger.

3.2 CONDUCTOR INSULATION AND MULTICONDUCTOR CABLE APPLICATIONS AND WIRING METHODS

- A. Service Entrance: Type THHW or THHN-THWN, single conductors in raceway.
- B. Exposed Feeders: Type THHW or THHN-THWN, single conductors in raceway or Metal-clad cable, Type MC.
- C. Feeders Concealed in Ceilings, Walls, Partitions, and Crawlspace: Type THHW or THHN-THWN, single conductors in raceway or Metal-clad cable, Type MC.
- D. Feeders Concealed in Concrete, below Slabs-on-Grade, and Underground: Type THHW or THHN-THWN, single conductors in raceway.
- E. Exposed Branch Circuits, Including in Crawlspace: Type THHW or THHN-THWN, single conductors in raceway or Metal-clad cable, Type MC.
- F. Branch Circuits Concealed in Ceilings, Walls, and Partitions: Type THHW or THHN-THWN, single conductors in raceway or Metal-clad cable, Type MC.

- G. Branch Circuits Concealed in Concrete, below Slabs-on-Grade, and Underground: Type THHW or THHN-THWN, single conductors in raceway.
- H. Cord Drops and Portable Appliance Connections: Type SO, hard service cord with stainless-steel, wire-mesh, strain relief device at terminations to suit application.
- I. Class 1 Control Circuits: Type THHW or THHN-THWN, in raceway.
- J. Class 2 Control Circuits: Type THHW or THHN-THWN, in raceway.

3.3 INSTALLATION OF CONDUCTORS AND CABLES

- A. Conceal cables in finished walls, ceilings, and floors, unless otherwise indicated.
- B. Use manufacturer-approved pulling compound or lubricant where necessary; compound used must not deteriorate conductor or insulation. Do not exceed manufacturer's recommended maximum pulling tensions and sidewall pressure values.
- C. Use pulling means, including fish tape, cable, rope, and basket-weave wire/cable grips, that will not damage cables or raceway.
- D. Install exposed cables parallel and perpendicular to surfaces of exposed structural members, and follow surface contours where possible.
- E. Support cables according to Division 16 Section "Electrical Supports".
- F. Identify and color-code conductors and cables according to Division 16 Section "Electrical Identification."
- G. Tighten electrical connectors and terminals according to manufacturer's published torque-tightening values. If manufacturer's torque values are not indicated, use those specified in UL 486A and UL 486B.
- H. Make splices and taps that are compatible with conductor material and that possess equivalent or better mechanical strength and insulation ratings than unspliced conductors.
 - 1. Use oxide inhibitor in each splice and tap conductor for aluminum conductors.
- I. Wiring at Outlets: Install conductor at each outlet, with at least 12 inches (300 mm) of slack.

3.4 SLEEVE INSTALLATION FOR ELECTRICAL PENETRATIONS

- A. Coordinate sleeve selection and application with selection and application of firestopping specified in Division 7 Section "Through-Penetration Firestop Systems."
- B. Concrete Slabs and Walls: Install sleeves for penetrations unless core-drilled holes or formed openings are used. Install sleeves during erection of slabs and walls.
- C. Fire-Rated Assemblies: Install sleeves for penetrations of fire-rated floor and wall assemblies unless openings compatible with firestop system used are fabricated during construction of floor or wall.
- D. Cut sleeves to length for mounting flush with both wall surfaces.
- E. Extend sleeves installed in floors 2 inches (50 mm) above finished floor level.
- F. Size pipe sleeves to provide 1/4-inch (6.4-mm) annular clear space between sleeve and cable unless sleeve seal is to be installed.
- G. Seal space outside of sleeves with grout for penetrations of concrete and masonry and with approved joint compound for gypsum board assemblies.
- H. Interior Penetrations of Non-Fire-Rated Walls and Floors: Seal annular space between sleeve and cable, using joint sealant appropriate for size, depth, and location of joint according to Division 7 Section "Joint Sealants."
- I. Fire-Rated-Assembly Penetrations: Maintain indicated fire rating of walls, partitions, ceilings, and floors at cable penetrations. Install sleeves and seal with firestop materials according to Division 7 Section "Through-Penetration Firestop Systems."
- J. Roof-Penetration Sleeves: Seal penetration of individual cables with flexible boot-type flashing units applied in coordination with roofing work.
- K. Aboveground Exterior-Wall Penetrations: Seal penetrations using sleeves and mechanical sleeve seals. Size sleeves to allow for 1-inch (25-mm) annular clear space between pipe and sleeve for installing mechanical sleeve seals.
- L. Underground Exterior-Wall Penetrations: Install cast-iron "wall pipes" for sleeves. Size sleeves to allow for 1-inch (25-mm) annular clear space between cable and sleeve for installing mechanical sleeve seals.

3.5 SLEEVE-SEAL INSTALLATION

- A. Install to seal underground exterior-wall penetrations.

- B. Use type and number of sealing elements recommended by manufacturer for cable material and size. Position cable in center of sleeve. Assemble mechanical sleeve seals and install in annular space between cable and sleeve. Tighten bolts against pressure plates that cause sealing elements to expand and make watertight seal.

3.6 FIRESTOPPING

- A. Apply firestopping to electrical penetrations of fire-rated floor and wall assemblies to restore original fire-resistance rating of assembly according to Division 7 Section "Through-Penetration Firestop Systems."

3.7 FIELD QUALITY CONTROL

- A. Perform tests and inspections and prepare test reports.
- B. Tests and Inspections:
 - 1. After installing conductors and cables and before electrical circuitry has been energized, test[service entrance and feeder conductors, and conductors feeding the following critical equipment and services] for compliance with requirements.
 - 2. Perform each visual and mechanical inspection and electrical test stated in NETA Acceptance Testing Specification. Certify compliance with test parameters.
- C. Test Reports: Prepare a written report to record the following:
 - 1. Test procedures used.
 - 2. Test results that comply with requirements.
 - 3. Test results that do not comply with requirements and corrective action taken to achieve compliance with requirements.
- D. Remove and replace malfunctioning units and retest as specified above.

END OF SECTION 16120

SECTION 16130 - RACEWAYS & BOXES

PART 1 - GENERAL

1.1 SUMMARY

- A. This Section includes raceways, fittings, boxes, enclosures, and cabinets for electrical wiring.

1.2 SUBMITTALS

- A. Product Data: For surface raceways, wireways and fittings, floor boxes, hinged-cover enclosures, and cabinets.
- B. Shop Drawings: For custom enclosures and cabinets. Include plans, elevations, sections, details, and attachments to other work.

1.3 QUALITY ASSURANCE

- A. Electrical Components, Devices, and Accessories: Listed and labeled as defined in NFPA 70, Article 100, by a testing agency acceptable to authorities having jurisdiction, and marked for intended use.
- B. Comply with NFPA 70.

PART 2 - PRODUCTS

2.1 METAL CONDUIT AND TUBING

- A. EMT: ANSI C80.3.
- B. Fittings for Conduit (Including all Types and Flexible and Liquidtight), EMT, and Cable: NEMA FB 1; listed for type and size raceway with which used, and for application and environment in which installed.
 - 1. Fittings for EMT: Steel or die-cast, set-screw or compression type.

2.2 METAL WIREWAYS

- A. Available Manufacturers: Subject to compliance with requirements, manufacturers offering products that may be incorporated into the Work include, but are not limited to, the following:

- B. Manufacturers: Subject to compliance with requirements, provide products by one of the following:
 - 1. Cooper B-Line, Inc.
 - 2. Hoffman.
 - 3. Square D; Schneider Electric.
- C. Description: Sheet metal sized and shaped as indicated, NEMA 250, Type 1, unless otherwise indicated.
- D. Fittings and Accessories: Include couplings, offsets, elbows, expansion joints, adapters, hold-down straps, end caps, and other fittings to match and mate with wireways as required for complete system.
- E. Wireway Covers: As indicated.
- F. Finish: Manufacturer's standard enamel finish.

2.3 SURFACE RACEWAYS

- A. Surface Metal Raceways: Galvanized steel with snap-on covers. Manufacturer's standard enamel finish in color selected by Architect.
 - 1. Available Manufacturers: Subject to compliance with requirements, manufacturers offering products that may be incorporated into the Work include, but are not limited to, the following:
 - 2. Manufacturers: Subject to compliance with requirements, provide products by one of the following:
 - a. Thomas & Betts Corporation.
 - b. Walker Systems, Inc.; Wiremold Company (The).
 - c. Wiremold Company (The); Electrical Sales Division.

2.4 BOXES, ENCLOSURES, AND CABINETS

- A. Sheet Metal Outlet and Device Boxes: NEMA OS 1.
- B. Small Sheet Metal Pull and Junction Boxes: NEMA OS 1.
 - 1. Metal Enclosures: Steel, finished inside and out with manufacturer's standard enamel.
 - 2. Nonmetallic Enclosures: Plastic finished inside with radio-frequency-resistant paint.
- C. Cabinets:

1. NEMA 250, Type 1, galvanized-steel box with removable interior panel and removable front, finished inside and out with manufacturer's standard enamel.
2. Hinged door in front cover with flush latch and concealed hinge.
3. Key latch to match panelboards.
4. Metal barriers to separate wiring of different systems and voltage.
5. Accessory feet where required for freestanding equipment.

PART 3 - EXECUTION

3.1 RACEWAY APPLICATION

- A. Comply with the following indoor applications, unless otherwise indicated:
1. Exposed: EMT.
 2. Concealed in Ceilings and Interior Walls and Partitions: EMT (MC Cable may be used in interior walls only).
 3. Boxes and Enclosures: NEMA 250, Type 1, except use NEMA 250, Type 4, nonmetallic in damp or wet locations.
- B. Minimum Raceway Size: 3/4-inch (16-mm) trade size.
- C. Raceway Fittings: Compatible with raceways and suitable for use and location.

3.2 INSTALLATION

- A. Comply with NECA 1 for installation requirements applicable to products specified in Part 2 except where requirements on Drawings or in this Article are stricter.
- B. Keep raceways at least 6 inches (150 mm) away from parallel runs of flues and steam or hot-water pipes. Install horizontal raceway runs above water and steam piping.
- C. Complete raceway installation before starting conductor installation.
- D. Support raceways as specified in Division 16 Section "Electrical Supports and Seismic Restraints."
- E. Arrange stub-ups so curved portions of bends are not visible above the finished slab.
- F. Install no more than the equivalent of three 90-degree bends in any conduit run except for communications conduits, for which fewer bends are allowed.
- G. Conceal conduit and EMT within finished walls, ceilings, and floors, unless otherwise indicated.

- H. Raceways Embedded in Slabs:
1. Run conduit larger than 1-inch (27-mm) trade size, parallel or at right angles to main reinforcement. Where at right angles to reinforcement, place conduit close to slab support.
 2. Arrange raceways to cross building expansion joints at right angles with expansion fittings.
- I. Raceway Terminations at Locations Subject to Moisture or Vibration: Use insulating bushings to protect conductors, including conductors smaller than No. 4 AWG.
- J. Install pull wires in empty raceways. Use polypropylene or monofilament plastic line with not less than 200-lb (90-kg) tensile strength. Leave at least 12 inches (300 mm) of slack at each end of pull wire.
- K. Raceways for Optical Fiber and Communications Cable: Install as follows:
1. 3/4-Inch (19-mm) Trade Size and Smaller: Install raceways in maximum lengths of 50 feet (15 m).
 2. 1-Inch (25-mm) Trade Size and Larger: Install raceways in maximum lengths of 75 feet (23 m).
 3. Install with a maximum of four 90-degree bends or equivalent for each length of raceway unless Drawings show stricter requirements. Separate lengths with pull or junction boxes or terminations at distribution frames or cabinets where necessary to comply with these requirements.
- L. Install raceway sealing fittings at suitable, approved, and accessible locations and fill them with listed sealing compound. For concealed raceways, install each fitting in a flush steel box with a blank cover plate having a finish similar to that of adjacent plates or surfaces. Install raceway sealing fittings at the following points:
1. Where conduits pass from warm to cold locations, such as boundaries of refrigerated spaces.
 2. Where otherwise required by NFPA 70.
- M. Flexible Conduit Connections: Use maximum of 72 inches (1830 mm) of flexible conduit for recessed and semirecessed lighting fixtures equipment subject to vibration, noise transmission, or movement; and for transformers and motors.
1. Use LFMC in damp or wet locations subject to severe physical damage.
 2. Use LFMC or LFNC in damp or wet locations not subject to severe physical damage.
- N. Recessed Boxes in Masonry Walls: Saw-cut opening for box in center of cell of masonry block, and install box flush with surface of wall.
- O. Set metal floor boxes level and flush with finished floor surface.

- P. Set nonmetallic floor boxes level. Trim after installation to fit flush with finished floor surface.

3.3 FIRESTOPPING

- A. Apply firestopping to electrical penetrations of fire-rated floor and wall assemblies to restore original fire-resistance rating of assembly. Firestopping materials and installation requirements are specified in Division 7 Section "Through-Penetration Firestop Systems."

END OF SECTION 16130

SECTION 16140 - WIRING DEVICES

PART 1 - GENERAL

1.1 SUMMARY

- A. This Section includes the following:
 - 1. Receptacles, receptacles with integral GFCI, and associated device plates.
 - 2. Communications outlets.

1.2 SUBMITTALS

- A. Product Data: For each type of product indicated.
- B. Shop Drawings: List of legends and description of materials and process used for pre-marking wall plates.
- C. Samples: One for each type of device and wall plate specified, in each color specified.
- D. Operation and Maintenance Data: For wiring devices to include in all manufacturers' packing label warnings and instruction manuals that include labeling conditions.

1.3 QUALITY ASSURANCE

- A. Electrical Components, Devices, and Accessories: Listed and labeled as defined in NFPA 70, Article 100, by a testing agency acceptable to authorities having jurisdiction, and marked for intended use.
- B. Comply with NFPA 70.

PART 2 - PRODUCTS

2.1 MANUFACTURERS

- A. Manufacturers' Names: Shortened versions (shown in parentheses) of the following manufacturers' names are used in other Part 2 articles:
 - 1. Cooper Wiring Devices; a division of Cooper Industries, Inc. (Cooper).
 - 2. Hubbell Incorporated; Wiring Device-Kellems (Hubbell).
 - 3. Leviton Mfg. Company Inc. (Leviton).
 - 4. Pass & Seymour/Legrand; Wiring Devices & Accessories (Pass & Seymour).

2.2 STRAIGHT BLADE RECEPTACLES

- A. Convenience Receptacles, 125 V, 20 A: Comply with NEMA WD 1, NEMA WD 6 configuration 5-20R, and UL 498.
 - 1. Available Products: Subject to compliance with requirements, products that may be incorporated into the Work include, but are not limited to, the following:
 - 2. Products: Subject to compliance with requirements, provide one of the following:
 - a. Cooper; 5351 (single), 5352 (duplex).
 - b. Hubbell; HBL5351 (single), CR5352 (duplex).
 - c. Leviton; 5891 (single), 5352 (duplex).
 - d. Pass & Seymour; 5381 (single), 5352 (duplex).

2.3 GFCI RECEPTACLES

- A. General Description: Straight blade, feed through type. Comply with NEMA WD 1, NEMA WD 6, UL 498, and UL 943, Class A, and include indicator light that is lighted when device is tripped.
- B. Duplex GFCI Convenience Receptacles, 125 V, 20 A:
 - 1. Available Products: Subject to compliance with requirements, products that may be incorporated into the Work include, but are not limited to, the following:
 - 2. Products: Subject to compliance with requirements, provide one of the following:
 - a. Cooper; GF20.
 - b. Pass & Seymour; 2084.

2.4 SNAP SWITCHES

- A. Comply with NEMA WD 1 and UL 20.
- B. Switches, 120/277 V, 20 A:
 - 1. Available Products: Subject to compliance with requirements, products that may be incorporated into the Work include, but are not limited to, the following:
 - 2. Products: Subject to compliance with requirements, provide one of the following:
 - a. Cooper; 2221 (single pole), 2222 (two pole), 2223 (three way), 2224 (four way).
 - b. Hubbell; CS1221 (single pole), CS1222 (two pole), CS1223 (three way), CS1224 (four way).
 - c. Leviton; 1221-2 (single pole), 1222-2 (two pole), 1223-2 (three way), 1224-2 (four way).
 - d. Pass & Seymour; 20AC1 (single pole), 20AC2 (two pole), 20AC3 (three way), 20AC4 (four way).

2.5 COMMUNICATIONS SYSTEM

OCCC Standard Bill of Material 2013 - PANDUIT			
DESCRIPTION	OEM	QUANTITY	OEM#
CABLE			
CAT6 PVC	PANDUIT		PUR6C04BU-UY
CAT6 PLENUM	PANDUIT		PUP6C04BU-UY
JACKS			
CAT6 JACKS	PANDUIT		CJ688TGIW
CAT6 JACKS	PANDUIT		CJ688TGOR
CAT6 JACKS	PANDUIT		CJ688TGBU
CAT6 JACKS	PANDUIT		CJ688TGYL
CAT6 JACKS	PANDUIT		CJ688TGLV
PATCH CABLES CAT6 WITH COLOR BREAKDOWN			
PATCH CABLES CAT6	PANDUIT		UTPSP3Y-XX
PATCH CABLES CAT6	PANDUIT		UTPSP5Y-XX
PATCH CABLES CAT6	PANDUIT		UTPSP7Y-XX
PATCH CABLES CAT6	PANDUIT		UTPSP10Y-XX
FOR COLORS ADD SUFFIX BELOW AFTER THE NUMBER AND PUT A Y AT THE END			
WHITE			WH
BLUE			BU
ORANGE			OR
VIOLET			VL
YELLOW			YL
FACEPLATE			
SINGLE GANG, SLOPED VERTICAL, ACCEPTS 2 MINI COMS	PANDUIT		CFPSL2IWY
SINGLE GANG, SLOPED VERTICAL, ACCEPTS 4 MINI COMS	PANDUIT		CFPSL4IWY
SINGLE GANG, SLOPED VERTICAL, ACCEPTS 6 MINI COMS	PANDUIT		CFPSL6IWY
BLANK FILLER MODULE	PANDUIT		CMBBL-X
RACKS & CABINETS			
WALL MOUNT RELAY RACK 38"	CPI		11791-718
RELAY RACK 7'	PANDUIT		CMR19X84
RELAY RACK 7'	PANDUIT		NFR84
SECURE PATCH 11RU FRONT ONLY	PATHWAYS		PS-11U-6PK
SECURE PATCH 11RU FRONT & REAR	PATHWAYS		PS-D11U-6PK
SECURE PATCH 22RU FRONT ONLY	PATHWAYS		PS-22U-6PK
SECURE PATCH 22RU FRONT & REAR	PATHWAYS		PS-D22U-6PK
SECURE PATCH 44RU FRONT ONLY	PATHWAYS		PS-44U-6PK
SECURE PATCH 44RU FRONT & REAR	PATHWAYS		PS-D44U-6PK
WALL MOUNT CABINET 38"	CPI		12419-736
WALL MOUNT CABINET 48"	CPI		12419-748
CABINET 42RU FREE STANDING W/VERTICAL MANAGEMENT 31" WIDE 42" DEPTH	PANDUIT		N8212B

OCCC Standard Bill of Material 2013 - PANDUIT			
DESCRIPTION	OEM	QUANTITY	OEM#
PAN ZONE CABINETS			
WALL MOUNT CABINET	PANDUIT		PZAEWM3
FAN KIT	PANDUIT		PZAEFAN
LOCK KIT	PANDUIT		PZAELOCK
HIGH DENSITY MODULAR PATCH PANEL	PANDUIT		CPP48HDEWBLY
PATCH PANEL			
HIGH DENSITY MODULAR PATCH PANEL	PANDUIT		CPP48HDEWBLY
24-PORT MODULAR PATCH PANEL	PANDUIT		CPPL24WBLY
48-PORT MODULAR PATCH PANEL	PANDUIT		CPPL48WBLY
WIRE MANAGEMENT			
HORIZONTAL 1U DUCTED MANAGER FRONT/REAR	PANDUIT		NM1
HORIZONTAL 1U DUCTED MANAGER FRONT ONLY	PANDUIT		NMF1
HORIZONTAL 2U DUCTED MANAGER FRONT/REAR	PANDUIT		NM2
VERTICAL MANAGER DUCTED FRONT/REAR	PANDUIT		WMPV45E
VERTICAL MANAGER DUCTED FRONT/REAR	PANDUIT		PRV10
VERTICAL MANAGER DOOR	PANDUIT		PRD10
FIBER PRODUCT			
SINGLEMODE OFNR 12-STRAND	CORNING		012E81-33131-24
SINGLEMODE OFNR 24-STRAND	CORNING		024E81-33131-24
SINGLEMODE OFNR 48-STRAND	CORNING		048E81-61131-24
SINGLEMODE OFNR 72-STRAND	CORNING		072E81-T3131-24
SINGLEMODE OFNR 96-STRAND	CORNING		096E81-T3131-24
SINGLEMODE OFNP 12-STRAND	CORNING		012E88-33131-29
SINGLEMODE OFNP 24-STRAND	CORNING		024E88-33131-29
SINGLEMODE OFNP 48-STRAND	CORNING		048E88-61131-24
SINGLEMODE OFNP 72-STRAND	CORNING		072E88-T3131-24
SINGLEMODE OFNP 96-STRAND	CORNING		096E88-T3131-24
SINGLEMODE INTERLOCKING ARMOR OFNR 12-STRAND	CORNING		012E81-31131-A1
SINGLEMODE INTERLOCKING ARMOR OFNR 24-STRAND	CORNING		024E81-31131-A1
SINGLEMODE INTERLOCKING ARMOR OFNR 48-STRAND	CORNING		048E81-61131-A1
SINGLEMODE INTERLOCKING ARMOR OFNR 72-STRAND	CORNING		072E81-T3131-A1
SINGLEMODE INTERLOCKING ARMOR OFNR 96-STRAND	CORNING		096E81-T3131-A1
SINGLEMODE INTERLOCKING ARMOR OFNP 12-STRAND	CORNING		012E88-33131-A3
SINGLEMODE INTERLOCKING ARMOR OFNP 24-STRAND	CORNING		024E88-33131-A3
SINGLEMODE INTERLOCKING ARMOR OFNP 48-STRAND	CORNING		048E88-61131-A3
SINGLEMODE INTERLOCKING ARMOR OFNP 72-STRAND	CORNING		072E88-T3131-A3
SINGLEMODE INTERLOCKING ARMOR OFNP 96-STRAND	CORNING		096E88-T3131-A3
RACK MOUNT FIBER PANEL 1RU	PANDUIT		FRME1U
RACK MOUNT FIBER PANEL 2RU	PANDUIT		FRME2U
RACK MOUNT FIBER PANEL 4RU	PANDUIT		FRME4U
COUPLER PANELS LOADED SINGLEMODE SC	PANDUIT		FAP6WBUDSCZ
COUPLER PANEL BLANK	PANDUIT		FAPB
RACK MOUNT FIBER PANEL 1RU	CORNING		CCH-01U
RACK MOUNT FIBER PANEL 2RU	CORNING		CCH-02U
RACK MOUNT FIBER PANEL 4RU	CORNING		CCH-04U
COUPLER PANELS LOADED SINGLEMODE SC	CORNING		CCH-CP12-59
SINGLEMODE SC UNICAM	CORNING		95-200-41

2.6 WALL PLATES

- A. Single and combination types to match corresponding wiring devices.
 - 1. Plate-Securing Screws: Metal with head color to match plate finish.
 - 2. Material for Finished Spaces: Smooth, high-impact thermoplastic [0.035-inch- (1-mm-)
 - 3. Material for Unfinished Spaces: Smooth, high-impact thermoplastic.
 - 4. Material for Damp Locations: Cast aluminum with spring-loaded lift cover, and listed and labeled for use in "wet locations."
- B. Wet-Location, Weatherproof Cover Plates: NEMA 250, complying with type 3R weather-resistant die-cast aluminum with lockable cover.

2.7 FLOOR SERVICE FITTINGS

- A. Type: Modular, flush-type, dual-service units suitable for wiring method used.
- B. Compartments: Barrier separates power from voice and data communication cabling.
- C. Service Plate: Rectangular, die-cast aluminum with satin finish.
- D. Power Receptacle: NEMA WD 6 configuration 5-20R, gray finish, unless otherwise indicated.
- E. Voice and Data Communication Outlet: Blank cover with bushed cable opening.

2.8 FINISHES

- A. Color: Wiring device catalog numbers in Section Text do not designate device color.
 - 1. Wiring Devices Connected to Normal Power System: White, unless otherwise indicated or required by NFPA 70 or device listing.
 - 2. Wiring Devices Connected to Emergency Power System: Red.
 - 3. TVSS Devices: Blue.

PART 3 - EXECUTION

3.1 INSTALLATION

- A. Comply with NECA 1, including the mounting heights listed in that standard, unless otherwise noted.
- B. Coordination with Other Trades:

1. Take steps to insure that devices and their boxes are protected. Do not place wall finish materials over device boxes and do not cut holes for boxes with routers that are guided by riding against outside of the boxes.
2. Keep outlet boxes free of plaster, drywall joint compound, mortar, cement, concrete, dust, paint, and other material that may contaminate the raceway system, conductors, and cables.
3. Install device boxes in brick or block walls so that the cover plate does not cross a joint unless the joint is troweled flush with the face of the wall.
4. Install wiring devices after all wall preparation, including painting, is complete.

C. Conductors:

1. Do not strip insulation from conductors until just before they are spliced or terminated on devices.
2. Strip insulation evenly around the conductor using tools designed for the purpose. Avoid scoring or nicking of solid wire or cutting strands from stranded wire.
3. The length of free conductors at outlets for devices shall meet provisions of NFPA 70, Article 300, without pigtails.
4. Existing Conductors:
 - a. Cut back and pigtail, or replace all damaged conductors.
 - b. Straighten conductors that remain and remove corrosion and foreign matter.
 - c. Pigtailing existing conductors is permitted provided the outlet box is large enough.

D. Device Installation:

1. Replace all devices that have been in temporary use during construction or that show signs that they were installed before building finishing operations were complete.
2. Keep each wiring device in its package or otherwise protected until it is time to connect conductors.
3. Do not remove surface protection, such as plastic film and smudge covers, until the last possible moment.
4. Connect devices to branch circuits using pigtails that are not less than 6 inches (152 mm) in length.
5. When there is a choice, use side wiring with binding-head screw terminals. Wrap solid conductor tightly clockwise, 2/3 to 3/4 of the way around terminal screw.
6. Use a torque screwdriver when a torque is recommended or required by the manufacturer.
7. When conductors larger than No. 12 AWG are installed on 15- or 20-A circuits, splice No. 12 AWG pigtails for device connections.
8. Tighten unused terminal screws on the device.
9. When mounting into metal boxes, remove the fiber or plastic washers used to hold device mounting screws in yokes, allowing metal-to-metal contact.

E. Receptacle Orientation:

1. Install ground pin of vertically mounted receptacles down, and on horizontally mounted receptacles to the left.

F. Device Plates: Do not use oversized or extra-deep plates. Repair wall finishes and remount outlet boxes when standard device plates do not fit flush or do not cover rough wall opening.

G. Dimmers:

1. Install dimmers within terms of their listing.
2. Verify that dimmers used for fan speed control are listed for that application.
3. Install unshared neutral conductors on line and load side of dimmers according to manufacturers' device listing conditions in the written instructions.

H. Arrangement of Devices: Unless otherwise indicated, mount flush, with long dimension vertical and with grounding terminal of receptacles on top. Group adjacent switches under single, multigang wall plates.

3.2 IDENTIFICATION

A. Comply with Division 16 Section "Electrical Identification."

1. Receptacles: Identify panelboard and circuit number from which served. Use hot, stamped or engraved machine printing with white-filled lettering on face of plate, and durable wire markers or tags inside outlet boxes.

3.3 FIELD QUALITY CONTROL

A. Perform tests and inspections and prepare test reports.

1. Test Instruments: Use instruments that comply with UL 1436.
2. Test Instrument for Convenience Receptacles: Digital wiring analyzer with digital readout or illuminated LED indicators of measurement.

B. Tests for Convenience Receptacles:

1. Line Voltage: Acceptable range is 105 to 132 V.
2. Percent Voltage Drop under 15-A Load: A value of 6 percent or higher is not acceptable.
3. Ground Impedance: Values of up to 2 ohms are acceptable.
4. GFCI Trip: Test for tripping values specified in UL 1436 and UL 943.
5. Using the test plug, verify that the device and its outlet box are securely mounted.

6. The tests shall be diagnostic, indicating damaged conductors, high resistance at the circuit breaker, poor connections, inadequate fault current path, defective devices, or similar problems. Correct circuit conditions, remove malfunctioning units and replace with new, and retest as specified above.

END OF SECTION 16140

SECTION 16289 - TRANSIENT VOLTAGE SUPPRESSION

PART 1 - GENERAL

1.1 SUMMARY

- A. This Section includes TVSSs for low-voltage power equipment.

1.2 SUBMITTALS

- A. Product Data: For each type of product indicated. Include rated capacities, operating weights, operating characteristics, furnished specialties, and accessories.
- B. Field quality-control test reports.
- C. Operation and Maintenance Data.

1.3 QUALITY ASSURANCE

- A. Source Limitations: Obtain suppression devices and accessories through one source from a single manufacturer.
- B. Electrical Components, Devices, and Accessories: Listed and labeled as defined in NFPA 70, Article 100, by a testing agency acceptable to authorities having jurisdiction, and marked for intended use.
- C. Comply with IEEE C62.41, "IEEE Guide for Surge Voltages in Low Voltage AC Power Circuits," and test devices according to IEEE C62.45, "IEEE Guide on Surge Testing for Equipment Connected to Low-Voltage AC Power Circuits."
- D. Comply with NEMA LS 1, "Low Voltage Surge Protection Devices."
- E. Comply with UL 1283, "Electromagnetic Interference Filters," and UL 1449, "Transient Voltage Surge Suppressors."

1.4 PROJECT CONDITIONS

- A. Service Conditions: Rate surge protection devices for continuous operation under the following conditions, unless otherwise indicated:
 - 1. Maximum Continuous Operating Voltage: Not less than 115 percent of nominal system operating voltage.
 - 2. Operating Temperature: 30 to 120 deg F (0 to 50 deg C).
 - 3. Humidity: 0 to 85 percent, noncondensing.
 - 4. Altitude: Less than 20,000 feet (6090 m) above sea level.

PART 2 - PRODUCTS

2.1 MANUFACTURERS

- A. Available Manufacturers: Subject to compliance with requirements, manufacturers offering products that may be incorporated into the Work include, but are not limited to, the following:
- B. Manufacturers: Subject to compliance with requirements, provide products by one of the following:
 - 1. Advanced Protection Technologies, Inc.
 - 2. Atlantic Scientific.
 - 3. Current Technology, Inc.
 - 4. Cutler-Hammer, Inc.; Eaton Corporation.
 - 5. Entelec International.
 - 6. General Electric Company.
 - 7. Innovative Technology, Inc.
 - 8. Intermatic, Inc.
 - 9. LEA International.
 - 10. Leviton Mfg. Company Inc.
 - 11. Liebert Corporation; a division of Emerson.
 - 12. Northern Technologies, Inc.
 - 13. Siemens Energy & Automation, Inc.
 - 14. Square D; Schneider Electric.
 - 15. Surge Suppression Incorporated.
 - 16. Sutton Designs Inc.
 - 17. Transtector Systems, Inc.
 - 18. Tycor; Cutler-Hammer, Inc.
 - 19. United Power Corporation.
 - 20. Zero Surge Inc.

2.2 PANELBOARD SUPPRESSORS

- A. Surge Protection Device Description: Non-modular, sine-wave-tracking type with the following features and accessories:
 - 1. LED indicator lights for power and protection status.
 - 2. Audible alarm, with silencing switch, to indicate when protection has failed.
 - 3. Fuses, rated at 200-kA interrupting capacity.
 - 4. Integral disconnect switch.
 - 5. Redundant suppression circuits.
 - 6. Surge-event operations counter.
- B. Peak Single-Impulse Surge Current Rating: 160 kA per phase.
- C. Protection modes and UL 1449 suppressed voltage rating for grounded wye circuits with voltages of 480Y/277, 208Y/120, 3-phase, 4-wire circuits shall be as follows:

1. Line to Neutral: 800 V for 480Y/277, 400 V for 208Y/120.
 2. Line to Ground: 800 V for 480Y/277, 400 V for 208Y/120
 3. Neutral to Ground: 800 V for 480Y/277, 400 V for 208Y/120
- D. Protection modes and UL 1449 suppressed voltage rating for 240/120-V, single-phase, 3-wire circuits shall be as follows:
1. Line to Neutral: 400 V.
 2. Line to Ground: 400 V.
 3. Neutral to Ground: 400 V.
- E. Protection modes and UL 1449 suppressed voltage rating for 240/120-V, 3-phase, 4-wire circuits with high leg shall be as follows:
1. Line to Neutral: 400 V, 800 V from high leg.
 2. Line to Ground: 400 V.
 3. Neutral to Ground: 400 V.
- F. Protection modes and UL 1449 suppressed voltage rating for voltages of 240 or 480, 3-phase, 3-wire, delta circuits shall be as follows:
1. Line to Line: 2000 V for 480 V, 1000 V for 240 V.
 2. Line to Ground: 1500 V for 480 V, 800 V for 240 V.

2.3 SUPPRESSORS FOR ELECTRONIC-GRADE PANELBOARDS

- A. Surge Protection Device Description: Sine-wave-tracking type, panel-mounted design with the following features and accessories:
1. LED indicator lights for power and protection status.
 2. Audible alarm, with silencing switch, to indicate when protection has failed.
 3. Arrangement with wire connections to phase buses, neutral bus, and ground bus.
- B. Peak Single-Impulse Surge Current Rating: 160kA per phase.
- C. Protection modes and UL 1449 suppressed voltage rating for grounded wye circuits with voltages of 480Y/277, 208Y/120, 3-phase, 4-wire circuits shall be as follows:
1. Line to Neutral: 800 V for 480Y/277, 400 V for 208Y/120
 2. Line to Ground: 800 V for 480Y/277, 400 V for 208Y/120
 3. Neutral to Ground: 800 V for 480Y/277, 400 V for 208Y/120
- D. Protection modes and UL 1449 suppressed voltage rating for 240/120-V, single-phase, 3-wire circuits shall be as follows:
1. Line to Neutral: 400 V.
 2. Line to Ground: 400 V.
 3. Neutral to Ground: 400 V.

- E. Protection modes and UL 1449 suppressed voltage rating for 240/120-V, 3-phase, 4-wire circuits with high leg shall be as follows:
 - 1. Line to Neutral: 400 V, 800 V from high leg.
 - 2. Line to Ground: 400 V.
 - 3. Neutral to Ground: 400 V.

- F. Protection modes and UL 1449 suppressed voltage rating for voltages of 240, 480, or 600, 3-phase, 3-wire, delta circuits shall be as follows:
 - 1. Line to Line: 2000 V for 480 V, 1000 V for 240 V.
 - 2. Line to Ground: 1500 V for 480 V, 800 V for 240 V.

2.4 ENCLOSURES

- A. NEMA 250, with type matching the enclosure of panel or device being protected.

PART 3 - EXECUTION

3.1 INSTALLATION OF SURGE PROTECTION DEVICES

- A. Install devices at service entrance on load side, with ground lead bonded to service entrance ground.

- B. Install devices for panelboard and auxiliary panels with conductors or buses between suppressor and points of attachment as short and straight as possible. Do not exceed manufacturer's recommended lead length. Do not bond neutral and ground.
 - 1. Provide multipole, 30, 60 or 100]-A circuit breaker as a dedicated disconnect for suppressor, unless otherwise indicated.

3.2 PLACING SYSTEM INTO SERVICE

- A. Do not energize or connect panelboards to their sources until surge protection devices are installed and connected.

3.3 FIELD QUALITY CONTROL

- A. Testing: Perform the following field tests and inspections and prepare test reports:
 - 1. Complete startup checks according to manufacturer's written instructions.
 - 2. Perform each visual and mechanical inspection and electrical test stated in NETA ATS, "Surge Arresters, Low-Voltage Surge Protection Devices" Section. Certify compliance with test parameters.

END OF SECTION 16289

SECTION 16410 - ENCLOSED SWITCHES & CIRCUIT BREAKERS

PART 1 - GENERAL

1.1 SUMMARY

- A. This Section includes the following individually mounted, enclosed switches and circuit breakers:
 - 1. Fusible switches.
 - 2. Nonfusible switches.
 - 3. Molded-case circuit breakers.
 - 4. Enclosures.

1.2 SUBMITTALS

- A. Product Data: For each type of enclosed switch, circuit breaker, accessory, and component indicated.
- B. Shop Drawings: Diagram power, signal, and control wiring.
- C. Field quality-control test reports.
- D. Operation and maintenance data.

1.3 QUALITY ASSURANCE

- A. Electrical Components, Devices, and Accessories: Listed and labeled as defined in NFPA 70, Article 100, by a testing agency acceptable to authorities having jurisdiction, and marked for intended use.
- B. Comply with NFPA 70.

PART 2 - PRODUCTS

2.1 MANUFACTURERS

- A. In other Part 2 articles where titles below introduce lists, the following requirements apply to product selection:
 - 1. Available Manufacturers: Subject to compliance with requirements, manufacturers offering products that may be incorporated into the Work include, but are not limited to, manufacturers specified.

2. Manufacturers: Subject to compliance with requirements, provide products by one of the manufacturers specified.

2.2 FUSIBLE AND NONFUSIBLE SWITCHES

A. Manufacturers:

1. Eaton Corporation; Cutler-Hammer Products.
2. General Electric Co.; Electrical Distribution & Control Division.
3. Siemens Energy & Automation, Inc.
4. Square D/Group Schneider.

- ### B. Fusible Switch, 600 A and Smaller: NEMA KS 1, Type HD, with clips or bolt pads to accommodate specified fuses, lockable handle with capability to accept two padlocks, and interlocked with cover in closed position.

- ### C. Nonfusible Switch, 600A and Smaller: NEMA KS 1, Type HD, lockable handle with capability to accept two padlocks, and interlocked with cover in closed position.

D. Accessories:

1. Equipment Ground Kit: Internally mounted and labeled for copper and aluminum ground conductors.
2. Neutral Kit: Internally mounted; insulated, capable of being grounded, and bonded; and labeled for copper and aluminum neutral conductors.
3. Auxiliary Contact Kit: Auxiliary set of contacts arranged to open before switch blades open.

2.3 MOLDED-CASE CIRCUIT BREAKERS AND SWITCHES

A. Manufacturers:

1. Eaton Corporation; Cutler-Hammer Products.
2. General Electric Co.; Electrical Distribution & Control Division.
3. Moeller Electric Corporation.
4. Siemens Energy & Automation, Inc.
5. Square D/Group Schneider.

- ### B. Molded-Case Circuit Breaker: NEMA AB 1, with interrupting capacity to meet available fault currents.

1. Thermal-Magnetic Circuit Breakers: Inverse time-current element for low-level overloads and instantaneous magnetic trip element for short circuits. Adjustable magnetic trip setting for circuit-breaker frame sizes 250 A and larger.
2. Adjustable Instantaneous-Trip Circuit Breakers: Magnetic trip element with front-mounted, field-adjustable trip setting.

3. Current-Limiting Circuit Breakers: Frame sizes 400 A and smaller and let-through ratings less than NEMA FU 1, RK-5.
4. GFCI Circuit Breakers: Single- and two-pole configurations with [5]-mA trip sensitivity.

C. Molded-Case Circuit-Breaker Features and Accessories:

1. Standard frame sizes, trip ratings, and number of poles.
2. Lugs: Mechanical style with compression lug kits suitable for number, size, trip ratings, and conductor material.
3. Application Listing: Type SWD for switching fluorescent lighting loads; Type HACR for heating, air-conditioning, and refrigerating equipment.
4. Ground-Fault Protection: Integrally mounted relay and trip unit with adjustable pickup and time-delay settings, push-to-test feature, and ground-fault indicator.
5. Shunt Trip: 120-V trip coil energized from separate circuit, set to trip at 55 percent of rated voltage.

2.4 ENCLOSURES

A. NEMA AB 1 and NEMA KS 1 to meet environmental conditions of installed location.

1. Outdoor Locations: NEMA 250, Type 3R.
2. Kitchen Areas: NEMA 250, Type 4X, stainless steel.
3. Other Wet or Damp Indoor Locations: NEMA 250, Type 4.

PART 3 - EXECUTION

3.1 INSTALLATION

- A. Coordinate size and location of concrete bases. Verify structural requirements with structural engineer.
- B. Concrete base is specified in Division 16 Section "Basic Electrical Materials and Methods Electrical Supports and Seismic Restraints," and concrete materials and installation requirements are specified in Division 3.
- C. Comply with applicable portions of NECA 1, NEMA PB 1.1, and NEMA PB 2.1 for installation of enclosed switches and circuit breakers.
- D. Mount individual wall-mounting switches and circuit breakers with tops at uniform height, unless otherwise indicated. Anchor floor-mounting switches to concrete base.
- E. Comply with mounting and anchoring requirements specified in Division 16 Section "Seismic Controls for Electrical Work Electrical Supports and Seismic Restraints."

- F. Temporary Lifting Provisions: Remove temporary lifting eyes, channels, and brackets and temporary blocking of moving parts from enclosures and components.
- G. Identify field-installed conductors, interconnecting wiring, and components; provide warning signs as specified in Division 16 Section "Electrical Identification."

3.2 FIELD QUALITY CONTROL

- A. Prepare for acceptance testing as follows:
 - 1. Inspect mechanical and electrical connections.
 - 2. Verify switch and relay type and labeling verification.
 - 3. Verify rating of installed fuses.
- B. Perform the following field tests and inspections and prepare test reports:
 - 1. Perform each electrical test and visual and mechanical inspection stated in NETA ATS, Section 7.5 for switches and Section 7.6 for molded-case circuit breakers. Certify compliance with test parameters.
 - 2. Correct malfunctioning units on-site, where possible, and retest to demonstrate compliance; otherwise, replace with new units and retest.

END OF SECTION 16410

SECTION 16442 - PANELBOARDS

PART 1 - GENERAL

1.1 SUMMARY

- A. This Section includes distribution panelboards and lighting and appliance branch-circuit panelboards.

1.2 SUBMITTALS

- A. Product Data: For each type of panelboard, overcurrent protective device, accessory, and component indicated. Include dimensions and manufacturers' technical data on features, performance, electrical characteristics, ratings, and finishes.
- B. Shop Drawings: For each panelboard and related equipment.
 - 1. Dimensioned plans, elevations, sections, and details. Show tabulations of installed devices, equipment features, and ratings. Include the following:
 - a. Enclosure types and details for types other than NEMA 250, Type 1.
 - b. Bus configuration, current, and voltage ratings.
 - c. Short-circuit current rating of panelboards and overcurrent protective devices.
 - d. UL listing for series rating of installed devices.
 - e. Features, characteristics, ratings, and factory settings of individual overcurrent protective devices and auxiliary components.
 - 2. Wiring Diagrams: Power, signal, and control wiring.
 - 3. Field quality-control test reports.
 - 4. Operation and maintenance data.

1.3 QUALITY ASSURANCE

- A. Electrical Components, Devices, and Accessories: Listed and labeled as defined in NFPA 70, Article 100, by a testing agency acceptable to authorities having jurisdiction, and marked for intended use.
- B. Comply with NEMA PB 1.
- C. Comply with NFPA 70.

PART 2 - PRODUCTS

2.1 MANUFACTURERS

- A. Available Manufacturers: Subject to compliance with requirements, manufacturers offering products that may be incorporated into the Work include, but are not limited to, the following:
- B. Manufacturers: Subject to compliance with requirements, provide products by one of the following:
 - 1. Panelboards, Overcurrent Protective Devices, Controllers, Contactors, and Accessories:
 - a. Eaton Corporation; Cutler-Hammer Products.
 - b. General Electric Co.; Electrical Distribution & Protection Div.
 - c. Siemens Energy & Automation, Inc.
 - d. Square D.

2.2 MANUFACTURED UNITS

- A. Enclosures: Flush- and surface mounted cabinets. NEMA PB 1, Type 1.
 - 1. Rated for environmental conditions at installed location.
 - a. Indoor Locations: NEMA 250, Type 1.
 - b. Other Wet or Damp Indoor Locations: NEMA 250, Type 3R
 - 2. Front: Secured to box with concealed trim clamps. For surface-mounted fronts, match box dimensions; for flush-mounted fronts, overlap box.
 - 3. Hinged Front Cover: Entire front trim hinged to box and with standard door within hinged trim cover.
- B. Phase and Ground Buses: Hard-drawn copper, 98 percent conductivity.
- C. Conductor Connectors: Suitable for use with conductor material.
 - 1. Ground Lugs and Bus Configured Terminators: Compression type.
- D. Service Equipment Label: UL labeled for use as service equipment for panelboards with main service disconnect switches.
- E. Future Devices: Mounting brackets, bus connections, and necessary appurtenances required for future installation of devices.
- F. Panelboard Short-Circuit Rating:
 - 1. UL label indicating series-connected rating with integral or remote upstream overcurrent protective devices. Include size and type of upstream device

allowable, branch devices allowable, and UL series-connected short-circuit rating.

2.3 DISTRIBUTION PANELBOARDS

- A. Doors: Secured with vault-type latch with tumbler lock; keyed alike. Omit for fused-switch panelboards.
- B. Main Overcurrent Protective Devices: Circuit breaker or Fused switch.
- C. Branch Overcurrent Protective Devices:
 - 1. For Circuit-Breaker Frame Sizes 125 A and Smaller: Plug-in circuit breakers.
 - 2. For Circuit-Breaker Frame Sizes Larger Than 125 A: Bolt-on circuit breakers; plug-in circuit breakers where individual positive-locking device requires mechanical release for removal.
 - 3. Fused switches.

2.4 LIGHTING AND APPLIANCE BRANCH-CIRCUIT PANELBOARDS

- A. Branch Overcurrent Protective Devices: Plug-in circuit breakers, replaceable without disturbing adjacent units.
- B. Doors: Concealed hinges; secured with flush latch with tumbler lock; keyed alike.
- C. Non-Dimmed Panels "ND" as defined in the DSL documents are to be equipped with micro-processor based programmable logic controllers as manufactured by Eaton and of the "Power Command" style or "Lyn Tec" style.

2.5 OVERCURRENT PROTECTIVE DEVICES

- A. Molded-Case Circuit Breaker: UL 489, with series-connected rating to meet available fault currents.
 - 1. Thermal-Magnetic Circuit Breakers: Inverse time-current element for low-level overloads, and instantaneous magnetic trip element for short circuits. Adjustable magnetic trip setting for circuit-breaker frame sizes 250 A and larger.
 - 2. GFCI Circuit Breakers: Single- and two-pole configurations with 5-mA trip sensitivity.
 - 3. Molded-Case Circuit-Breaker Features and Accessories: Standard frame sizes, trip ratings, and number of poles.
 - a. Lugs: Compression style, suitable for number, size, trip ratings, and conductor materials.
 - b. Application Listing: Appropriate for application; Type SWD for switching fluorescent lighting loads; Type HACR for heating, air-conditioning, and refrigerating equipment.

- c. Shunt Trip: 120-V trip coil energized from separate circuit, set to trip at 55 percent of rated voltage.
- B. Fused Switch: NEMA KS 1, Type HD; clips to accommodate specified fuses; lockable handle.
- C. Fuses are specified in Division 16 Section "Fuses."

2.6 CONTROLLERS

- A. Motor Controllers: NEMA ICS 2, Class A, combination controller equipped for panelboard mounting and including the following accessories:
 - 1. Individual control-power transformers.
 - 2. Fuses for control-power transformers.
 - 3. Bimetallic-element overload relay.
 - 4. Indicating lights.
 - 5. Seal-in contact.
 - 6. 2 convertible auxiliary contacts.
 - 7. Push buttons.
 - 8. Selector switches.
- B. Contactors: NEMA ICS 2, Class A, combination controller equipped for panelboard mounting and including the following accessories:
 - 1. Individual control-power transformers.
 - 2. Fuses for control-power transformers.
 - 3. Indicating lights.
 - 4. Seal-in contact.
 - 5. 2 convertible auxiliary contacts.
 - 6. Push buttons.
 - 7. Selector switches.
- C. Controller Disconnect Switches: Fused switch mounted adjacent to and interlocked with controller.
 - 1. Auxiliary Contacts: Integral with disconnect switches to de-energize external control-power source.
- D. Contactors in Main Bus: NEMA ICS 2, Class A, mechanically held general-purpose controller.
 - 1. Control-Power Source: Control-power transformer, with fused primary and secondary terminals, connected to main bus ahead of contactor connection.
 - 2. Control-Power Source: 120-V branch circuit.

2.7 ACCESSORY COMPONENTS AND FEATURES

- A. Furnish accessory set including tools and miscellaneous items required for overcurrent protective device test, inspection, maintenance, and operation.
- B. Furnish portable test set to test functions of solid-state trip devices without removal from panelboard.
- C. Fungus Proofing: Permanent fungicidal treatment for panelboard interior, including overcurrent protective devices and other components.

PART 3 - EXECUTION

3.1 INSTALLATION

- A. Install panelboards and accessories according to NEMA PB 1.1.
- B. Comply with mounting and anchoring requirements specified in Division 16 Section " r Electrical Work Electrical Supports."
- C. Mount top of trim 74 inches (1880 mm) above finished floor, unless otherwise indicated.
- D. Mount plumb and rigid without distortion of box. Mount recessed panelboards with fronts uniformly flush with wall finish.
- E. Install overcurrent protective devices and controllers.
 - 1. Set field-adjustable switches and circuit-breaker trip ranges.
- F. Install filler plates in unused spaces.
- G. Stub four 1-inch (27-GRC) empty conduits from panelboard into accessible ceiling space or space designated to be ceiling space in the future. Stub four 1-inch (27-GRC) empty conduits into raised floor space or below slab not on grade.
- H. Identify field-installed conductors, interconnecting wiring, and components; provide warning signs as specified in Division 16 Section "Electrical Identification."
- I. Panelboard Nameplates: Label each panelboard with engraved metal or laminated-plastic nameplate mounted with corrosion-resistant screws.
- J. Ground equipment according to Division 16 Section "Grounding and Bonding."
- K. Connect wiring according to Division 16 Section "Conductors and Cables."

3.2 FIELD QUALITY CONTROL

- A. Prepare for acceptance tests as follows:
 - 1. Test insulation resistance for each panelboard bus, component, connecting supply, feeder, and control circuit.
 - 2. Test continuity of each circuit.

- B. Perform the following field tests and inspections and prepare test reports:
 - 1. Perform each electrical test and visual and mechanical inspection stated in NETA ATS, Section 7.5 for switches and Section 7.6 for molded-case circuit breakers. Certify compliance with test parameters.
 - 2. Correct malfunctioning units on-site, where possible, and retest to demonstrate compliance; otherwise, replace with new units and retest.

END OF SECTION 16442